



# Picture Framers GUILD

**NEWSLETTER**

**FEBRUARY 1997**

## 1997 PPFA FRAMING COMPETITION PRINTS ARE NOW AVAILABLE

Just a reminder that time is drawing short for our Print Framing competition, scheduled for May 3 and 4 this year (more about this later), with the winner of the Guild competition advancing to the National PPFA competition to be held in Cincinnati, OH, Oct 1997. Interested?

The print, chosen at the Las Vegas Convention last fall, is..... "POPPIES" by Georgia O'Keefe. The unusual aspect is that the "print" is the sheet of stamps, available at your local Post Office!!

I would suggest that you purchase your sheet soon, as supplies are somewhat limited. If we run out locally, the Guild can order from the national office. The good news is, if you procrastinate getting it framed, (as some of us are prone to do), you can always put the stamps on outgoing mail!

One word of warning: the judges will treat the sheet of stamps as a Limited Edition, deserving of appropriate treatment in framing.

Entries from EPFG in the National competition have always done very well- wining top prize in several tries, as did The Frame Dame in last year's competition. Now's the time to show your abilities and creativity!

### REMINDER!

January started a new dues year for EPFG and PPFA. Membership in EPFG is included in your PPFA membership, but if you choose not to belong to PPFA, EPFG annual dues are \$40.00. Checks can be mailed to:

**Paul Knoop, Treasurer**  
6742 W 19th Street  
University Place, WA 98466

## FEBRUARY 11 MEETING AT CRANBROOK GALLERY SEATTLE DESIGN CENTER

5601 6th Avenue S, Seattle

### Topic: Printmaking and the Framer

The framer's knowledge of the media being framed is more critical today than ever before. Jeff Schulman's presentation will enlighten you and also entertain you with some of the latest in fine art.

### DRIVING DIRECTIONS:

From I-5, take **Exit 161- S Michigan Street**; Turn **right on 6th Avenue South**, go a few blocks (just past RR tracks). The Design Center is on the left, with parking in front of the building.

Cranbrook is the former Winn showroom.

## KAYE EVANS WILL BE KEYNOTE SPEAKER AT 1997 EPFG EDUCATION PROGRAM AND BANQUET

Kaye Evans, a premier educator in the framing industry, will be this year's banquet speaker, plus will offer either a full-day class or tow half-day classes on Sunday, May 4.

In addition to being a custom framer for over 20 years, Kaye has impressive credentials in the education field. She received her teacher certification from Purdue University, is the Director of the Academy of Creative Arts and Framing, is a member of the PPFA teaching staff, and has published two books and 11 how-to video tapes.

Kaye recently completed five TV segments for the Home and Garden Network, and is doing another segment

*(Continued on page 2)*

*inside...*

1997 Education Program	Page 1
EPFG Group Insurance Program	Page 2
EPFG Library Listing; Meeting Notes	Page 7
Classified ads	Page 7
Calendar, Officers & Board	Page 8

*Happy Valentine's Day!*

## EPFG WORKING ON GROUP INSURANCE OFFERINGS

Considerable interest has been shown in the subject of insurance for art and frame shops, and the Board believes that a group approach to insurance can bring significant benefits to member shops.

The EPFG Board officially got the ball rolling by authorizing surveys of its membership by two agencies, one for general business/ liability insurance, and another for health/ medical insurance.

The Bell Anderson Agency will be doing the general insurance work, and Karen Beck Insurance will be handling the Health side of it. Survey details are not firm, but members can expect to receive survey information from both of them within the next month or so. Please watch for them, and please respond.

Both of these firms are well established, with outstanding qualifications and abilities to do the job for us. More later!

*(Continued from page 1) KAYE EVANS*

for PBS. She is a contributing editor to Picture Framing Magazine and writes for several publications in the craft and needlart industry.

Ask any of Kaye's students and they will tell you that teaching is a passion with her, as evidenced by her course's high standards and the return visits to her classroom. We feel fortunate to have such an outstanding talent participating in this year's program.



**FRAMERS' INVENTORY**  
*Specializing in the Fine Art of Service.*

**STILL GROWING!**

WOOD MOULDINGS  
ARQUATI, BAY, FRAMERS' INVENTORY,  
LA MARCHE, MAX, PIEDMONT, SENELAR,  
WILLIAMSON

METAL MOULDING  
DESIGNER & NIELSON

MATBOARD  
BAINBRIGE, CRESCENT, MILLER

C&H AND FLETCHER FRAMING EQUIPMENT  
SEAL MOUNTING EQUIPMENT.

5000 S.E. 18TH AVENUE, PORTLAND, OR. 97202  
TOLL FREE# 1(800)543-2467

# NATIONAL GLASS

17030 WOODINVILLE-REDMOND ROAD, WOODINVILLE, WA. 98072

**QUALITY PRODUCTS AND EXCELLENT SERVICE!** NATIONAL GLASS INVENTORIES THE LARGEST SELECTION OF PICTURE FRAMING GLASS IN THE PACIFIC NORTHWEST.



NATIONAL GLASS

**TRU VUE AND SANDEL PREMIUM, REFLECTION CONTROL, SATINVIEW, CONSERVATION SERIES GLASS, IMAGE PERFECT, DENGLAS, AND CRYSTALVIEW.**

ALSO AVAILABLE: **FOAM-X, MIRROR AND ACRYLICS**

**EVERYTHING YOU NEED AND FREE DELIVERY ARE ONLY A PHONE CALL AWAY!**

(206) 488-8126

1(800) 521-7061

FAX (206) 488-3712

Same Day Service  
**Jayeness Moulding Co.**

Wholesale Picture  
 Frame Supplies

2928 4th Ave S • Seattle, WA 98134  
**206-292-9664**  
**800-423-6287**



**VICTOR MOULDING CO.**  
 977 66TH AVENUE, P.O. BOX 2236  
 OAKLAND, CA 94621 • 415-430-5400

WHOLESALE PICTURE FRAME SUPPLIES

CHUCK BIGFORD  
 SALES REPRESENTATIVE

(206) 481-2555

1-800-366-8429  
 1-415-430-8588 FAX

MESSAGE CENTER  
 1-800-359-2829  
 EXT 3715

**Bob Batic**  
 Sales Representative

10312 12th Ave. NW  
 Seattle, WA 98177  
 (206) 782-8888



 **TRUVUE / MILLER ARTBOARD**

 **STUDIO  
 MOULDING**

ORDER: (800) 262-4174  
 FAX: (206) 656-9125  
 LOCAL: (206) 656-2940

8214-B SOUTH 192nd ST., KENT WA 98032

- 5 chops: 5% Discount + Free Freight
- 10 chops: 10% Discount + Free Freight
- Length: Quantity Discount Available
- Routing Service

**Joseph Huber**  
 Sales Representative



695 Edgewater St. N.W.  
 Salem, Oregon 97304  
 Phone: 1-800-872-4445  
 FAX: 1-503-363-7273

21828 87th Ave. S.E., Suite B  
 Woodinville, WA 98072  
 Phone: 1-800-292-3202  
 FAX: 1-206-486-4978

 **ARQUATTI®**

**Jeffrey Schuffman**

Washington - Oregon Sales Representative

1433 W. Frankford Rd. #100 Carrollton, Texas 75007

800 527-0421 x 822  
 800 817-0524 Fax

NURRE CAXTON



**PAMELA NEAL**  
 Sales Representative  
 Washington, Wyoming, Montana  
 Oregon, Idaho

800-255-1942, p. 133 D, ext. 4011 voice mail  
 800-377-3300 fax  
 800-910-8966 pager

**Colorful, Creative,  
 Pure & Strong...**



**Crescent Rag Mat**  
**100% Cotton Museum Board**

The choice of Artists & Picture Framing Professionals,  
 for archival and conservation matting.  
 Acid-free and lignin-free.

Send in your business card to receive  
 your FREE Rag Mat Booklet (RM-100).

Crescent Cardboard Company 106 W. Willow Road, Wheeling, IL 60090 U.S.A.

Software suite for Windows, DOS & OS/2

New Version! Galleries & Frame shops User Friendly!

**FERENSOFT**

**TRIO!**

- Art
- Customers
- Framing

Business management suite includes original **FRAMESHOP™** software. See why people are switching to **FERENSOFT!** Seattle 206-282-1775.

Created by *Decor* columnist John Ferens, CPF.

(303) 466-9420  
 (800) 817-2737  
 FAX (303) 465-1771



**Humberto Ortiz**  
 National Sales Manager

2330 W. MIDWAY BLVD. • P.O. BOX 925 • BROOMFIELD, CO 80038-0925

Archive Mattboard • Burnich & Designer Moulding • Clark Moulding  
 Foamcore • Miller Mattboard • Piedmont Moulding  
 TruVue Glass • Williamson Moulding

METAL FRAMES ART



6010 EAST ALKI WAREHOUSE #3 SPOKANE, WASHINGTON 99212  
 PHONE 800 344-7329 509 535-1440 FAX 800 344-5003 509 535-3466

SEATTLE, WA 98133



**THE ART DOCTOR**  
 Restoration of Oil Paintings, Japanese Screens,  
 Art on Paper, Art Objects

**NANCY G. WHITE** (206) 783-9160  
 Restorer By Appointment

## HARTUNG GLASS INDUSTRIES

- ◆ Complete line of Acrylics; Clear, Non-Glare & UV.
- ◆ We carry Tru-View, Sandel & Crystalview
- ◆ Specializing in beveled mirrors for framing.
- ◆ Next day delivery from Everett to Tacoma.
- ◆ Over 20 years experience with picture framers.
- ◆ Call us and have a Customer Service Representative specializing in your needs help you.



17830 West Valley Highway, Seattle, WA 98188  
 (206)656-2626, (800)552-2227, FAX (206)656-2601

**JOIN THE THOUSANDS  
OF FRAMERS WHO ARE  
INCREASING THEIR PROFITS  
AND ENHANCING THEIR  
CREATIVITY BY OFFERING  
FABRIC-WRAPPED  
MATS AND LINERS ---**

*Think  
Fabric*

--- It is generally agreed that fabric-wrapped mats and liners enhance the beauty of any frame, but what is *not* so well-understood is that offering fabric wraps is very **easy to master**, highly **profitable**, and requires no large expenditure of time, money, or effort.

At **FRAMING FABRICS & MOULDING INTERNATIONAL** we offer everything you need to make this beautiful framing option available to your clients.

- *More than 400 Colors of Fabric*
- *An Extensive Selection of Liners*
- *Custom-Wrapped Mats and Liners*
- *Adhesives and Tools*
- *Excellent Sample Program*
- *Prompt Service, and more...*

Please take a moment to call us toll-free at 1-800-832-2742. Ask for Frank. He'll be happy to answer any questions you might have about fabric and its use in Custom Picture Framing.



6001 Santa Monica Blvd. • Los Angeles, California 90038  
<http://www.n-n-n.com/ffmi/> • e-mail [ffmi@n-n-n.com](mailto:ffmi@n-n-n.com)

# GILD A FRAME

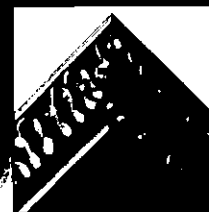

## GENUINE GOLD LEAF PRODUCTS FOR THE FRAMING INDUSTRY

A full line of genuine and composition gold leaf for every picture framing project. All products in stock for immediate delivery. No quantity too small or too large.

**Call (213)469-0856 today**  
for our complete price and  
product catalog



Easy Leaf Products

6001 Santa Monica Blvd. • Los Angeles, California 90038  
<http://www.n-n-n.com/elp/> • e-mail [elp@n-n-n.com](mailto:elp@n-n-n.com)



# Allegra.

Seven delicate embossed mouldings in two finishes of antique gold and antique silver.

For more information on new Allegra and other Larson-Juhl framing products call:  
(800) 438-5031

or contact your Larson-Juhl sales representative by calling (800) 223-0307

Stephen Dean - ext. 454 Paul Anderson - ext. 456  
Joe Garitone - ext. 455

**LARSON · JUHL**  
ADDING ARTISTRY TO ART  
WARMTH TO LIVING

# Nantucket.

Nantucket captures the essence of rustic seaside cottages, cheerful cranberry harvests and weathered lobster pots. Six finishes of Ivy, Acorn, Cypress, Cedar, Redwood and Chesapeake on two rough-sawn profiles create this memorable collection.

For more information on new Nantucket and other Larson-Juhl framing products call:  
(800) 438-5031

or contact your Larson-Juhl sales representative by calling (800) 223-0307

Stephen Dean - ext. 454 Paul Anderson - ext. 456  
Joe Garitone - ext. 455

**LARSON · JUHL**  
ADDING ARTISTRY TO ART  
WARMTH TO LIVING

## Chances are you started out with a LOGAN Mat Cutter Have you seen what we've done lately?

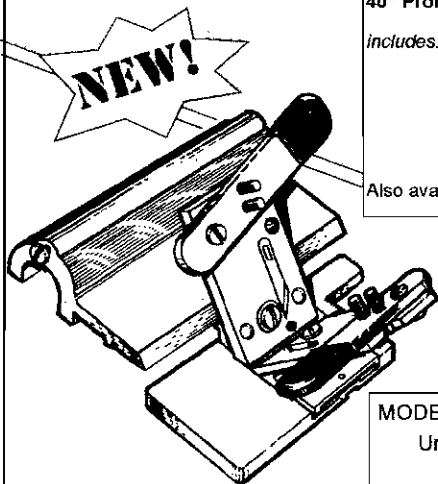

Model 705  
Logan  
V-Groover

### MODEL #650 *Framer's Edge* MAT CUTTER 40" Professional Production Matcutter

- Includes:
- Ergonomically designed Dual straight and Bevel cutting head
  - Production Stops
  - Parallel Mat Guide
  - Start and Stop Indicator for line to line cutting.
  - 27" Squaring Arm

**Suggested List Price \$599.95**

Also available in a 60" version MODEL #660 *Framer's Edge* \$799.95

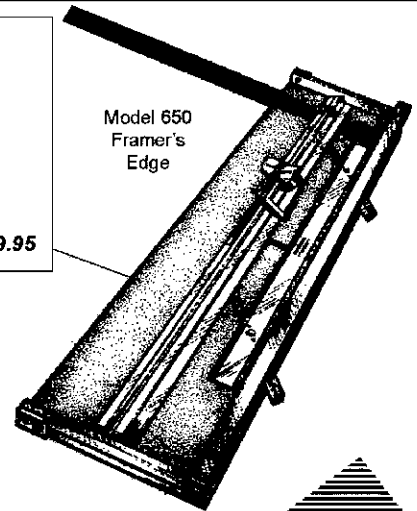

Model 650  
Framer's  
Edge

### MODEL 705 LOGAN V-Groover patented

Unique "push-pull" surface V-Groover that cuts beautiful V-Grooves on the surface of the matboard. Works entirely with stops provided for accurate V-Grooving in seconds with zero overcuts.  
Endless creative possibilities!!

**Suggested List Price \$125.00**

### MODEL 706 Universal V-Groover patented

Works on professional mat cutters using a 5/8" thick cutting bar rod including Fletcher® and C&H® professional matcutters.

**Suggested List Price \$150.00**



GRAPHIC PRODUCTS, INC.  
1100 BROWN STREET • WALCONDA, ILLINOIS 60084  
NATIONWIDE TOLL FREE 1-800/331-6232  
TOLL FREE FAX 800/331-6329

See us at <http://www.artproducts.com>  
E-MAIL Logan-Graphic-Products@worldnet.att.net

**JANUARY MEETING NOTES:**

Thanks to Art Laminators for their excellent hosting of the meeting, plus a tour of the facilities following the meeting.

Paul Knoop presented a method of quickly pricing a customer's framing order that he had developed for their shop. Also, ideas for meeting programs were discussed, which you will see reflected in future EPFG meeting plans.

Some of the requests were computer software, merchandising/advertising, insurance (see P 2), art appraisals, art & frame restorations, shop layout and lighting, resources guides, plus others. If you have a request, be sure to call an officer or board member and let them know!

**EPFG LIBRARY SELECTIONS****BOOKS**

Framers book of techniques and materials  
 Framers guide to Japanese papers  
 Picture Framing - Kistler I  
 Mat cutting- Kistler II  
 Needlework- Kistler III  
 Business Forms  
 Conservation Framing  
 Easy to build object box  
 Frames & framing  
 PPFA Guild: Guidelines for framing works of art on Paper  
 Guidelines for framing works of art on Canvas  
 Mounting, lamination, and texturizing  
 Matting & hinging  
 Marbling  
 Art of showing art  
 Beginners Guide to Faux Finishes  
 Guerrilla marketing  
 How to care for works of art  
 How to sell framing  
 Life of a photo  
 The Gilder's Manual  
 Practical Gilding

**VIDEOS**

Traditional gilding  
 Basics of matcutting/decorating  
 Basics of picture framing  
 Color selection in matting  
 Conservation framing - Bowen  
 Framing needlework  
 French mats & inlaid mats  
 Conservation framing needlear  
 Conservation framing - Kistler  
 Recognizing Graphic Art Techniques- FACTS

**GILDING TOOLS** -Gilder's pad, tip, & knife  
 Check out this basic set of gilding tools, along with the new books on gilding and develop your gilding skills!

These resources are available to members simply for the asking!  
 To arrange pickup, or to pick them up at a monthly meeting,  
 Contact: **EPFG Librarian,**

**ALLAN LAMB, CPF**  
**Lamb Cottage Gallery, Lynnwood**  
**(206) 776-1911**

Extreme Value



**THE WILLIAMSON CO.**  
 FINE MOULDINGS & FRAMES

Manufacturer & Distributor  
 OF QUALITY PICTURE FRAME MOULDING  
 AND READY MADE FRAMES

For more information, call your sales representative

**Sarah Lockhart**

1-800-851-2467

**CLASSIFIED ADS****EPFG NEWSLETTER****RULES AND RATES FOR CLASSIFIED ADS IN 1997**

- ◆ Members are allowed a free ad for up to 3 months running; a \$10/month fee will be billed for additional time.
- ◆ Non-members may place a classified ad at \$15/month.
- ◆ Product or service ads will be billed according to the display ad rate schedule.

The classified ads are offered to help you and your business!  
 Please use them- Any questions, call:

- Dave Allred, Newsletter Editor, at (206)455-0607, or
- Paul Knoop, EPFG Treasurer, at (206)564-2320

Let the Newsletter help you in 1997!

**BUSINESS FOR SALE**

**Profitable Custom Picture Framing Shop**  
**Long-term Lease Downtown Seattle**  
**Equipment & Inventory**  
**Phone Nabeel at (206) 441-6603**  
**Terms Negotiable**

2/97

**WANTED****Newsletter Editor(s)**

Use your communications and organization skills to help get out the Northwest framing news  
 For more info, contact any EPFG officer or  
**Dave Allred, Editor, (206)455-0607**

**FOR SALE**

**Save Space with Metal Flat-File Cabinets!**  
**6-Drawer, 28" x 17.5" x 4"**  
**Full Extension Hardware**  
**4 at \$185 each**  
**Contact Nick at (206) 633-1200**

2/97

1997

**January**  
 Tuesday, Jan 14 7:30 pm  
 CHAPTER MEETING  
 Art Laminators  
 206 105th Avenue NE  
 Bellevue (206)455-0607  
  
 Jan 28- EPFG Board Meeting

**February**  
 Tuesday, Feb 11 7:30 pm  
 CHAPTER MEETING  
 Cranbrook Gallery  
 Seattle Design Center  
 5601 8th Avenue S  
 Seattle

**March**  
 Tuesday, Mar 11 7:30 pm  
 CHAPTER MEETING  
 The Frame Makers  
 6724 W 19th Street  
 Tacoma (206)564-2320  
  
 Mar 25- EPFG Board Meeting

**April**  
 Tuesday, April 8 7:30 pm  
 CHAPTER MEETING  
  
 April 23 & 24  
 PPFA ED CONFERENCE  
 Vancouver, BC

**May**  
 EDUCATION  
 PROGRAM AND  
 BANQUET  
 Sat & Sun, May 3 & 4  
 DOUBLETREE INN,  
 TUKWILA  
  
 May 27- EPFG Board Meeting

**June**  
 Tuesday, June 10 7:30 pm  
 CHAPTER MEETING

**July**  
 Tuesday, July 8 7:30 pm  
 CHAPTER MEETING  
  
 July 29- EPFG Board Meeting

**August**  
 ANNUAL  
 EPFG PICNIC & BBQ  
  
 Date & Place  
 to be announced

**September**  
 Tuesday, Sept 9 7:30 pm  
 CHAPTER MEETING  
  
 Sept 23- EPFG Board Meeting

**October**  
 Tuesday, Oct 14 7:30 pm  
 CHAPTER MEETING

**November**  
 Tuesday, Nov 12 7:30 pm  
 CHAPTER MEETING  
  
 Nov 25- EPFG Board Meeting

**December**  
  
**NO MEETING**

**EVERGREEN** *Picture Framers' Guild*  
 C/O DAVID ALLRED, CPF  
 DIMENSIONS *Gallery & Framery, Inc.*  
 206 105th Avenue NE  
 Bellevue, WA 98004

**OFFICERS**

**PRESIDENT**

**FRANK LARSON, CPF**  
 LARSON FINE ART  
 SERVICES  
 (206)276-2082

**VICE PRESIDENT**

**JEFF SCHUFFMAN**  
 JEFFREY SCHUFFMAN &  
 ASSOCIATES  
 (206)223-1810

**TREASURER**

**PAUL KNOOP, CPF**  
 THE FRAME MAKERS  
 (206)564-2320

**SECRETARY**

**DONNA RICKMAN, CPF**  
 FINISHING TOUCHES  
 (206)338-0932

**PAST PRESIDENT**

**PAUL MILLER, CPF**  
 RAINDROPS GALLERY  
 (206)528-2832

**BOARD**

**JOHN FERENS, CPF**  
 FERENSOF  
 (206)282-1775

**ALLAN LAMB, CPF**  
 LAMB COTTAGE GALLERY.  
 (206)776-1911

**STEVE DEAN**

LARSON-JUHL  
 (206)433-6002

**JOE HUBER**

STUDIO MOULDING  
 (206)656-2940

**DEBORAH PITTMAN, CPF**

FAST FRAME  
 (206)471-9210

**NEWSLETTER:**

**DAVE ALLRED, CPF**  
 DIMENSIONS GALLERY &  
 FRAMERY  
 (206)455-0607



**Please recycle!**