

### SPOTLIGHT ON MAY PROGRAM

By this time EPFG membership should have received the registration materials for the 4th Annual Awards Banquet and Education program. This year's event will be conducted over a two day period, May 3 & 4. The location again this year is at the DoubleTree Inn in Tukwila. This event takes tremendous planning, by the Board and dedicated volunteers. The program for 1997 reflects those efforts. On Saturday May 3rd EPFG is playing host to PPFA's ReCertification Program. This seminar is required for those CPF's who received their designation after January 1, 1994, it is also recommended for all CPF's. The ReCertification Course covers recent innovations in framing, keeps CPF's current with advances in the field and maintains the value of the CPF credential. The RE Certification course is led by a team of experienced instructors with practical framing experience and expertise in preservation. Each faculty member has been trained in curriculum materials and effective training techniques. The instructor for the May 3rd course will be Dennis Tilley, CPF. The CPF exam will run concurrently on Saturday. Registration for this exam must be made through PPFA in Richmond, Virginia.

Sunday-May 4th marks the big day! Four classes will fill the day's education slate. The morning classes include National educator Kaye Evans, CPF presenting a program on Preservation Framing for fine art on paper. Evans has been an instructor for PPFA, Nielsen/Bainbridge and Williamson Moulding. Toby Freccia

*(Continued on page 2)*

### Framing Competitions to be featured in May

During the annual education program in May, the Evergreen Picture Framers' Guild will also sponsor the regional Print Framing competition and the chapter Open Framing competition. This is the qualifying event for those interested in advancing to PPFA's National Hall of Fame Competition in Cincinnati. Each entrant in the print competition will be framing a commemorative sheet of stamps featuring the work of Georgia O'Keefe. The stamps are enhanced with the image and words of the artist. Historically the EPFG winners have fared extremely well at the National Level, with several first place awards. The chapter prize structure for the print competition is:

1st place: Airfare to Cincinnati to compete at the National Level.

2nd place: \$100.00

3rd place: \$50.00

The award structure at the National Level presents as follows:

1st place: \$1,500.00 & featured on the front cover of *Picture Framing Magazine*

2nd place: \$300.00

3rd place: \$200.00

*(Continued on page 5)*

### Inside This Issue

- ◆ Banquet & Education Information
- ◆ Framing Competitions
- ◆ Classified Ads
- ◆ Clues (3)
- ◆ April Meeting Notes

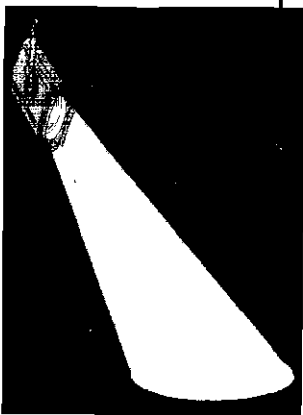

*Sunday-May 4th marks the big day!*

## Spotlight on May...

*(Continued from page 1)*

will be demonstrating his art of faux finishing as the second program to be held in the morning. Toby currently travel throughout the U.S. and Europe applying his talents to residential homes, restaurants and retail stores, such as Barney's. His techniques and designs are unique and highly creative. He will be demonstrating his methods as well as sharing hands on training for those in attendance. The afternoon programs will highlight preservation framing for needleart, again hosted by Kaye Evans. Linda Horsfall, CPF of Framers' Inventory will be conducting a traditional class on Basic and Intermediate Mat Cutting. Proper technique in mat cutting is essential to every framer and should be reviewed periodically. This class is also an excellent opportunity for new framers' to receive professional instruction.

The weekend event also features the Print framing competition and the Open competition. Judging will take place during the afternoon, with popular choice voting during the social hour. Winners of the framing competitions and the Vendor awards will be presented during the banquet. Our Key Note address will be delivered by Kaye Evans. So for those of you who are unable to participate in one of her classes this is your chance to share some of her insight to the framing industry.

The weekend has a variety of options and registration is underway. Check your registration packet for more specific times, costs, ballots and clues. Hope to see you there!

The EPFG is saddened to announce that Dave Allred of Dimensions Gallery suffered a heart attack on April 3rd and is in Overlake Hospital. We are keeping Dave and his family in our thoughts and prayers.



**FRAMERS' INVENTORY**  
*Specializing in the Fine Art of Service.*

**STILL GROWING!**

**WOOD MOULDINGS**  
ARQUATI, BAY, FRAMERS' INVENTORY,  
LA MARCHE, MAX, PIEDMONT, SENELAR,  
WILLIAMSON

**METAL MOULDING**  
DESIGNER & NIELSON

**MATBOARD**  
BAINBRIGE, CRESCENT, MILLER

C&H AND FLETCHER FRAMING EQUIPMENT  
SEAL MOUNTING EQUIPMENT.

5000 S.E. 18TH AVENUE, PORTLAND, OR. 97202  
TOLL FREE# 1(800)543-2467

# PORTICO.

*Eight uniquely crafted mouldings inspired from the fresco walls of European villas and the worn, layered look of painted antique furniture.*

For more information on new Portico and other Larson-Juhl framing products call:  
**(800) 438-5031**

or contact your Larson-Juhl sales representative  
by calling (800) 223-0307

Stephen Dean - ext. 454 Paul Anderson - ext. 456  
Joe Garitone - ext. 455

**LARSON · JUHL**  
ADDING ARTISTRY TO ART  
WARMTH TO LIVING

Same Day Service  
**Jayeness Moulding Co.**

Wholesale Picture  
 Frame Supplies  
 2928 4th Ave S • Seattle, WA 98134  
**206-292-9664**  
**800-423-6287**



**VICTOR MOULDING CO.**  
 977 66TH AVENUE, P.O. BOX 2206  
 OAKLAND, CA 94621 • 415-430-0400

**WHOLESALE PICTURE FRAME SUPPLIES**

CHUCK BIGFORD  
 SALES REPRESENTATIVE

(206) 481-2555

1-800-366-4428  
 1-415-430-8588 FAX

MESSAGE CENTER  
 1-800-359-2929  
 EXT 3715

**Bob Battie**  
 Sales Representative

10312 12th Ave. NW  
 Seattle, WA 98177  
 (206) 782-8888



**TRU VUE / MILLER ARTBOARD**



**ORDER: (800) 262-4174**  
**FAX: (206) 656-9125**  
**LOCAL: (206) 656-2940**

8214-B SOUTH 192nd ST., KENT WA 98032

- 5 chops: 5% Discount + Free Freight
- 10 chops: 10% Discount + Free Freight
- Length: Quantity Discount Available
- Routering Service

**Joseph Huber**  
 Sales Representative



695 Edgewater St. N.W.  
 Salem, Oregon 97304  
 Phone: 1-800-872-4445  
 FAX: 1-503-363-7273

21828 87th Ave. S.E., Suite B  
 Woodinville, WA 98072  
 Phone: 1-800-292-3202  
 FAX: 1-206-486-4978



**Jeffrey Schuffman**

Washington - Oregon Sales Representative  
 1433 W. Frankford Rd. #100 Carrollton, Texas 75007

800 527-0421 x 822  
 800 817-0524 Fax

NURRE CAXTON



**PAMELA NEAL**  
 Sales Representative  
 Washington, Wyoming, Montana  
 Oregon, Idaho

800-255-1942, press 6, ext. 4011 voice mail  
 800-377-3300 fax  
 800-910-8966 pager

**Colorful, Creative,  
 Pure & Strong...**



**Crescent Rag Mat**  
**100% Cotton Museum Board**

The choice of Artists & Picture Framing Professionals,  
 for archival and conservation matting.  
 Acid-free and lignin-free.

Send in your business card to receive  
 your FREE Rag Mat Booklet (RM-100).

Crescent Cardboard Company 100 W. Willow Road, Wheeling, IL 60090 U.S.A.

Software suite for Windows, DOS & OS/2  
 New Version! Galleries & Frame shops User Friendly!

**FERENSOFT**  
**TRIO!**

- Art
- Customers
- Framing

Business management suite includes original **FRAMESHOP™** software. See why people are switching to **FERENSOFT!**  
 Seattle 206-282-1775.  
 Created by *Decor* columnist John Ferens, CPF.



Extreme Value



**THE WILLIAMSON CO.**  
 FINE MOULDINGS & FRAMES

Manufacturer & Distributor  
 OF QUALITY PICTURE FRAME MOULDING  
 AND READY MADE FRAMES

For more information, call  
**Donna Gluyas**  
 Western Region Sales Manager  
 1-800-851-2467

Archive Mattboard • Burnich & Designer Moulding • Clark Moulding  
 Foamcore • Miller Mattboard • Piedmont Moulding  
 TruVue Glass • Williamson Moulding

METAL FRAMES ART



6010 EAST ALKI WAREHOUSE #5 SPOKANE, WASHINGTON 99212  
 PHONE 800 344-7329 509 535-3440 FAX 800 344-5003 509 535-3466

SEATTLE, WA 98133



**THE ART DOCTOR**  
 Restoration of Oil Paintings, Japanese Screens,  
 Art on Paper, Art Objects

**NANCY G. WHITE** (206) 783-9160  
 Restorer By Appointment

## HARTUNG GLASS INDUSTRIES

- ◆ Complete line of Acrylics; Clear, Non-Glare & UV.
- ◆ We carry Tru-View, Sandel & Crystalview
- ◆ Specializing in beveled mirrors for framing.
- ◆ Next day delivery from Everett to Tacoma.
- ◆ Over 20 years experience with picture framers.
- ◆ Call us and have a Customer Service Representative specializing in your needs help you.



17830 West Valley Highway, Seattle, WA 98188  
 (206)656-2626, (800)552-2227, FAX (206)656-2601

### April meeting notes- judging criteria

The April general chapter meeting was held on Tuesday the 8th at Frame Design Northwest in Issaquah. With 28 in attendance a review of the NEW judging criteria was presented. Over the past two years Jodi Norton and Linda Watson have been involved with PPFA in updating the criteria used in judging framing competitions. All the rules and restrictions were addressed, including the requirement of having a color slide of your entry upon registration at the National Level. This is a must for all pieces being judged in Cincinnati. The new criteria now includes much more specific details to be considered when judging. The point system remains essentially the same. Some of the key elements that were discussed was the use of multiple techniques. Judges are looking for a variety of techniques to be used in competition, however, they must be justified and work effortlessly with the piece. A competition piece should compliment the work it surrounds without distraction. It was also explained how the judges work. Initially the judges with stand back and scan the entire display of pieces to see which ones stand out and make the best overall impression. After that cursory evaluation the detailed judging begins. Once every element of the framing has been examined, the judges again stand back to insure that all the components flow smoothly from the art outward to the frame. This presentation was an bonus for those who are considering entering the competition locally in May.

A special thanks to Sue Bye and Shelly Bedsaul of Frame Dame/Blue Heron Gallery for providing some of their award winning framing as examples.

If you should have any questions regarding the EPFG or National Framing Competitions - please contact either Linda Watson or Jodi Norton of Frame Design Northwest at (206) 392-9727.

### Framing Competitions

*(Continued from page 1)*

The Open Framing competition is a chapter event. The Open competition has no restrictions on design or subject matter. The purpose is to encourage framers to invent new and creative techniques, or to combine traditional techniques for a new look. Those participating in the chapter event, must still qualify at the Cincinnati show. If they place in the preliminary judging the piece will advance to Hall of Fame judging. The EPFG is a chance to warm up before heading off to compete at National. The prize structure for the Open Framing Competition is as follows:

1st place: \$100.00

2nd & 3rd place: ribbons

The National Prize structure for the Open Competitions is:

1st place: \$1,500.00 and featured on the cover of *Picture Framing Magazine*

2nd place: \$300.00

3rd place: \$200.00

Now is the time to put your creative talents to work and reap the benefits of these competitions.

*The winner will receive \$1,500.00 and be featured on the cover of Picture Framing Magazine*



#### DANCE LESSONS

Learn to dance like  
Fred & Ginger  
classes forming in May  
Instruction to be held in the  
opulent ballroom of the  
Mansion d'Body  
1 800 211 feet  
police no longer believe the  
ballroom was the scene of the  
crime



(213) 469-0805



(213) 469-9006



(213) 469-0856

947 NORTH COLE AVENUE • LOS ANGELES, CALIFORNIA 90038 • FAX (213) 469-0940

## Try our UNIMOUNT Fabric Adhesive ---

*It's Clean* --- Water-soluble

*It's Effective* --- Works with mats and liners

*It's Versatile* --- Mounts posters, too!

*It's Economical* --- Costs just pennies per item

*It's Easy to Use* --- Simple and problem-free, and

*It's Environmentally Friendly* --- No harsh chemicals or solvents are used



**This adhesive** can be used to mount our heaviest liners and our lightest, most delicate silks. It is applied with a foam-type paint roller, and is ready to accept the fabric immediately. There is no waiting period, so you get done sooner. No equipment is needed, so you don't have to invest large sums of money. It's simple and easy to use, so you don't have to invest much time learning how to use it, either. It's versatile, strong, allows easy clean-up, and will take the "work" out of fabric-wrapping.

**Quart: \$10.50**

**Gallon: \$32.00**

**Fabric Mounting Kit** - Contains everything you need for professional results with your fabric-wrapped Mats and Liners: **\$30.00**

**Deluxe Kit (Includes 8" Dahle Scissors): \$50.00**

**1-800-8-FABRIC**

**1-800-832-2742**

# NATIONAL GLASS

17030 WOODINVILLE-REDMOND ROAD, WOODINVILLE, WA. 98072

**QUALITY PRODUCTS AND EXCELLENT SERVICE!** NATIONAL GLASS INVENTORIES THE LARGEST SELECTION OF PICTURE FRAMING GLASS IN THE PACIFIC NORTHWEST.



NATIONAL GLASS

TRU VUE AND SANDEL PREMIUM, REFLECTION CONTROL, SATINVIEW, CONSERVATION SERIES GLASS, IMAGE PERFECT, DENGLAS, AND CRYSTALVIEW.

ALSO AVAILABLE: *FOAM-X*, MIRROR AND ACRYLICS

EVERYTHING YOU NEED AND *FREE DELIVERY* ARE ONLY A PHONE CALL AWAY!

(206) 488-8126

1(800) 521-7061

FAX (206) 488-3712

## Chances are you started out with a LOGAN Mat Cutter Have you seen what we've done lately?

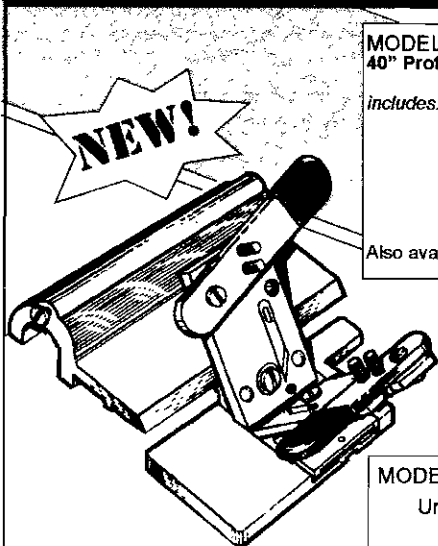

Model 705  
Logan  
V-Groover

**MODEL #650 *Framer's Edge* MAT CUTTER**  
40" Professional Production Matcutter

- includes:*
- Ergonomically designed Dual straight and Bevel cutting head
  - Production Stops
  - Parallel Mat Guide
  - Start and Stop Indicator for line to line cutting.
  - 27" Squaring Arm

**Suggested List Price \$599.95**

Also available in a 60" version MODEL #660 *Framer's Edge* \$799.95

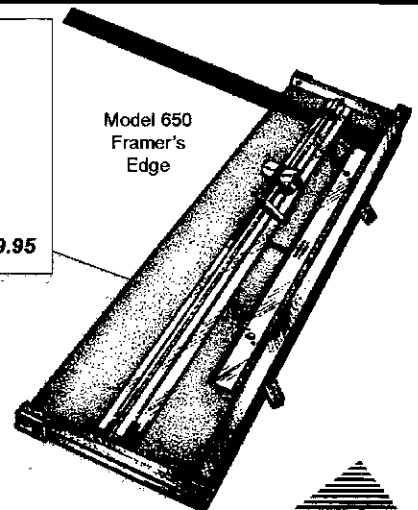

Model 650  
Framer's  
Edge

**MODEL 705 LOGAN V-Groover** patented

Unique "push-pull" surface V-Groover that cuts beautiful V-Grooves on the surface of the matboard. Works entirely with stops provided for accurate V-Grooving in seconds with zero overcuts. Endless creative possibilities!!

**Suggested List Price \$125.00**

**MODEL 706 Universal V-Groover** patented

Works on professional mat cutters using a 5/8" thick cutting bar rod including Fletcher® and C&H® professional matcutters.

**Suggested List Price \$150.00**



GRAPHIC PRODUCTS, INC.  
1100 BROWN STREET • WAUCONDA, ILLINOIS 60084  
NATIONWIDE TOLL FREE 1-800/331-6232  
TOLL FREE FAX 800/331-6329

See us at <http://www.artproducts.com>

E-MAIL [Logan-Graphic-Products@worldnet.att.net](mailto:Logan-Graphic-Products@worldnet.att.net)

# LIBRARY

## EPFG LIBRARY SELECTIONS

### BOOKS

Framers book of techniques and materials  
 Framers guide to Japanese papers  
 Picture Framing - Kistler I  
 Mat cutting- Kistler II  
 Needlework- Kistler III  
 Business Forms  
 Conservation Framing  
 Easy to build object box  
 Frames & framing  
 PPFA Guild: Guidelines for framing works of art on Paper  
                   Guidelines for framing works of art on Canvas  
 Mounting, lamination, and texturizing  
 Matting & hinging  
 Marbling  
 Art of showing art  
 Beginners Guide to Faux Finishes  
 Guerrilla marketing  
 How to care for works of art  
 How to sell framing  
 Life of a photo  
 The Gilder's Manual  
 Practical Gilding

### VIDEOS

Traditional gilding  
 Basics of matcutting/decorating  
 Basics of picture framing  
 Color selection in matting  
 Conservation framing - Bowen  
 Framing needlework  
 French mats & inlaid mats  
 Conservation framing needleart  
 Conservation framing - Kistler  
 Recognizing Graphic Art Techniques- FACTS

GILDING TOOLS -Gilder's pad, tip, & knife  
 Check out this basic set of gilding tools, along with the new  
 books on gilding and develop your gilding skills!

These resources are available to members simply for the asking!  
 To arrange pickup, or to pick them up at a monthly meeting,  
 Contact: EPFG Librarian,

**ALLAN LAMB, CPF**  
**Lamb Cottage Gallery, Lynnwood**  
**(206) 776-1911**

## CLASSIFIED ADS

### For Sale

Save Space with Metal Flat-File  
 Cabinets!

3 9-drawer cabinets, 28x17.5x 4  
 full extension hardware  
 \$185.00 per cabinet  
 Contact Nick at (206) 633-1200

### WANTED

Used single-or Double Miter Saw  
 Used V-nailer and compressor  
 Contact Norma at (360) 734-5497  
 1122 27th Street  
 Bellingham, WA 98225

### FOR SALE

Profitable established picture framing  
 business  
 Down Town - Low Rent - 5yr lease with  
 option  
 \$20K all equipment and inventory  
 (206) 441-6603

SWF recently cleared as a murder  
 suspect seeks elderly, financially secure  
 gentleman for companionship and long  
 term relationship.

contact MISS SCARLET

For Sale: collectors item! authentic  
 GET SMART revolver actually touched  
 by agent 99. Once considered as  
 murder weapon used against Mr.Body.





1997

<p><b>January</b></p>	<p><b>February</b></p>	<p><b>March</b></p>	<p><b>April</b></p>
<p><b>May</b>                  EPFG 4TH ANNUAL                  AWARDS BANQUET &amp;                  EDUCATION PROGRAM                  MAY 3 &amp; 4                  DOUBLE TREE INN-                  TUKWILA</p>	<p><b>June</b>                  Tuesday, June 10 7:30p.m.                  Chapter Meeting                  Studio Moulding                  8214-B S 192nd St.                  Kent (206) 656-2940                  photo handling &amp; restoration</p>	<p><b>July</b>                  Tuesday, July 8 7:30p.m.                  Chapter Meeting                  Art &amp; Framing software                  July 29-EPFG Board                  Meeting</p>	<p><b>August</b>                  Annual                  EPFG Picnic &amp; BBQ                  Date &amp; place to be                  announced</p>
<p><b>September</b>                  Tuesday, Sept 9 7:30 p.m.                  Chapter Meeting                  Shop &amp; Gallery Lighting                  Sept 23-EPFG Board                  Meeting</p>	<p><b>October</b>                  Tuesday, Oct 14 7:30 p.m.                  Chapter Meeting                  Color Trends for 1998</p>	<p><b>November</b>                  Tuesday, Nov 12 7:30 p.m.                  Chapter Meeting                  Holiday Tricks &amp; Treats                  Nov 25-EPFG Board                  Meeting</p>	<p><b>December</b>                  No Meeting                  Happy Holidays</p>

**Evergreen *Picture Framers' Guild***

c/o Paul Knoop, CPF  
 Frame Makers  
 6724 West 19th St.  
 Tacoma, WA 98466























