

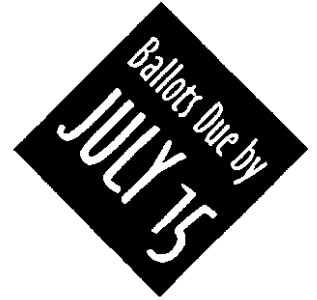

Picture Framers GUILD

July, 1997



EPFG President's Letter

We stand at an important point in the history of EPFG. Do we remain a part of PPFA or do we go our own way? Can we survive on our own?

One way to look at this is, "How does PPFA National affect the local chapter or organization, and vice versa?" PPFA states that they have two responsibilities to the chapter. One is that they collect the chapter's dues and remit them to the chapter quarterly and the other is to educate the Chapter Board members in how to manage a chapter. The Chapter's responsibility is to support PPFA and all its policies however it can and to make sure that all chapter members are members of PPFA National.

It's pretty sad that none of the above is actually happening. PPFA has collected but not dispersed the chapter dues to the chapters. What happened? The money got used to keep PPFA afloat during its recent financial crisis. This is exactly what we in EPFG predicted would happen long before the combined dues structure was passed and why we fought it for years. PPFA showed little interest in the local chapters until it saw additional revenue possibilities in collecting dues for them. All PPFA members pay chapter dues (\$25) even if there is no chapter in their area. Supposedly the dues collected from members with no chapters was to be saved and used for establishing new chapters. Where is that money now? Where are the chapters' dues? Gone, all gone. *(continued on page 7)*

EPFG Membership Vote on PPFA Affiliation

Ballots sent out; to be returned by July 15

EPFG membership is asked to vote on whether or not to continue affiliation with PPFA. Ballots, providing information on the pros and cons of being a chapter of PPFA or continuing as separate entity were mailed to the membership the last week of June. This action has been under consideration for the past several years, and has been discussed by many of the members at Board meetings and monthly meetings. The basic reason of dissatisfaction with policies and actions of the National organization was recently compounded by financial setbacks and a lack of openness, real and perceived, and frankness from the leadership at PPFA. Several other chapters have taken similar action in the recent past to disassociate from the National organization, the most recent being the folks to our South in Oregon, who are now the Columbia Picture Framers Guild.

While the new PPFA Executive Director is taking bold and vigorous steps *(continued on page 12)*

Another Winner!

Dick Nelson of Firland Gallery won First Place in the EPFG framing competition. Congratulations! Our apologies, too — Dick's achievement was inadvertently omitted from last month's newsletter.

In This Issue

- June meeting notes 9
- The library 9
- PPFA in financial trouble 10
- Classified ads 10
- EPFG picnic 12
- July meeting topic 13
- EPFG Officers and Board of Directors 13
- Calendar of upcoming events 14
- Thanks to Educational Weekend sponsors!

Gold Sponsor

Jayeness Moulding Co. Inc.

Molly Boone Neese
206.292.9664

*Thank You for Your Support of the Evergreen Picture Framers Guild
4th Annual Educational Weekend & Awards Banquet*

Gold Sponsor

Tru Vue

Stacy Kohn
800.621.8339

*Thank You for Your Support of the Evergreen Picture Framers Guild
4th Annual Educational Weekend & Awards Banquet*

NATIONAL GLASS

17030 WOODINVILLE-REDMOND ROAD, WOODINVILLE, WA. 98072

QUALITY PRODUCTS AND EXCELLENT SERVICE! NATIONAL GLASS INVENTORIES THE LARGEST SELECTION OF PICTURE FRAMING GLASS IN THE PACIFIC NORTHWEST.



NATIONAL GLASS

TRU VUE AND SANDEL PREMIUM, REFLECTION CONTROL, SATINVIEW, CONSERVATION SERIES GLASS, IMAGE PERFECT, DENGLAS, AND CRYSTALVIEW.

ALSO AVAILABLE: *FOAM-X*, MIRROR AND ACRYLICS

EVERYTHING YOU NEED AND *FREE DELIVERY* ARE ONLY A PHONE CALL AWAY!

(206) 488-8126

1(800) 521-7061

FAX (206) 488-3712

Chances are you started out with a LOGAN Mat Cutter Have you seen what we've done lately?

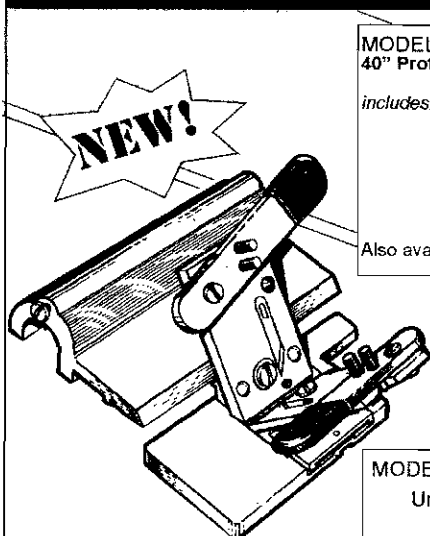

Model 705
Logan
V-Groover

MODEL #650 *Framer's Edge* MAT CUTTER 40" Professional Production Matcutter

- includes:
- Ergonomically designed Dual straight and Bevel cutting head
 - Production Stops
 - Parallel Mat Guide
 - Start and Stop Indicator for line to line cutting.
 - 27" Squaring Arm

Suggested List Price \$599.95

Also available in a 60" version MODEL #660 *Framer's Edge* \$799.95

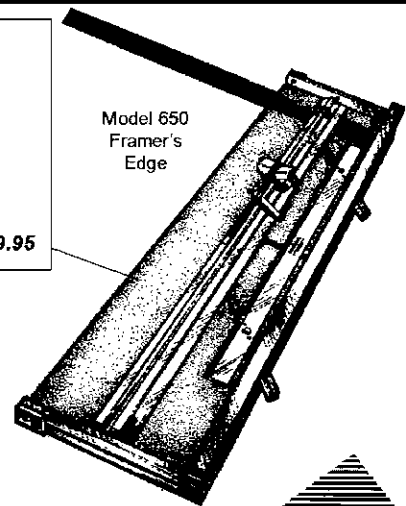

Model 650
Framer's
Edge

MODEL 705 LOGAN V-Groover patented

Unique "push-pull" surface V-Groover that cuts beautiful V-Grooves on the surface of the matboard. Works entirely with stops provided for accurate V-Grooving in seconds with zero overcuts.

Endless creative possibilities!!

Suggested List Price \$125.00

MODEL 706 Universal V-Groover patented

Works on professional mat cutters using a 5/8" thick cutting bar rod including Fletcher® and C&H® professional matcutters.

Suggested List Price \$150.00



GRAPHIC PRODUCTS, INC.
1100 BROWN STREET • WALKONDA, ILLINOIS 60084
NATIONWIDE TOLL FREE 1-800/331-8232
TOLL FREE FAX 800/531-6329

See us at <http://www.artproducts.com>

E-MAIL Logan-Graphic-Products@worldnet.att.net

Gold Sponsor

Designer Moulding

Jane Lande
800.533.6986 ext.432

*Thank You for Your Support of the Evergreen Picture Framers Guild
4th Annual Educational Weekend & Awards Banquet*

Gold Sponsor

Larson Juhl

Dan Guzzo
206.433.1617

*Thank You for Your Support of the Evergreen Picture Framers Guild
4th Annual Educational Weekend & Awards Banquet*



6001 Santa Monica Blvd., Los Angeles, CA 90038
Tel# (213) 469-9006 . Fax#(213) 469-0940

Date: _____
Ship Via: _____
Terms: _____
Order Number: _____

SOLD TO

Name: _____
Company: _____
Address: _____
City: _____ State _____ Zip _____
Telephone: () _____ Fax: () _____

SHIP TO

Name: _____
Company: _____
Address: _____
City: _____ State _____ Zip _____
Telephone: () _____ Fax: () _____

Photo Classics

All Frames Made in the USA

Name	Description Acrylics	Sizes					
		4x6	Qty.	5x7	Qty.	8x10	Qty.
Allegro	Vertical/Horizontal - Double Sided	\$29.75		\$39.75		\$66.00	
Concerto	Vertical	\$24.25		\$32.75		\$48.25	
Cantata	Vertical/Horizontal - Double Sided	\$29.75		\$39.75		\$66.00	
Rhapsody	Vertical	\$22.75		\$25.75		\$31.25	
Rhapsody	Horizontal	\$22.75		\$25.75		\$31.25	
Sonata	Vertical - Double Sided	\$20.75		\$23.75		\$29.25	
Sonata	Horizontal - Double Sided	\$20.75		\$23.75		\$29.25	
Symphony	Vertical/Horizontal	\$22.50		\$26.75		\$35.75	
Set of 24	Acrylic Frames	\$650.00 (\$768.25 value)					

Name	Description Hand Carved/Hand Finished/Seamless Corners	Sizes					
		4x6	Qty.	5x7	Qty.	8x10	Qty.
Antwerp	R/C Genuine Gold Leaf	\$60.00		\$67.50		\$75.00	
Barcelona	Antique Genuine Gold Leaf	\$60.00		\$67.50		\$75.00	
Bristol	Gen. Gold Leaf w/ Red to Show, Lt. Antique	\$60.00		\$67.50		\$75.00	
Budapest	Stripes, Gold	\$52.50		\$60.00		\$67.50	
Chelsea	Antique Silver Leaf	\$52.50		\$60.00		\$67.50	
Florence	Trim Moulding to 1/2" Deep, Antique GGL	\$52.50		\$60.00		\$67.50	
Genoa	Sp. Carved Flowers on Cor. Only. All GGL	\$60.00		\$67.50		\$75.00	
Lisbon	Gold Leaf	\$45.00		\$52.50		\$60.00	
Lyon	Small Leaf Detail in Cor., Antique GGL	\$60.00		\$67.50		\$75.00	
Madrid	White Gold Black Sides	\$60.00		\$67.50		\$75.00	
Oslo	Natural Maple	\$37.50		\$45.00		\$52.50	
Prague	GGL over Colors, Black Panel, No Cor. Detail	\$60.00		\$67.50		\$75.00	
Turin	All White Gold	\$60.00		\$67.50		\$75.00	
Vienna	Crackled Genuine Gold Leaf/Black Lip	\$60.00		\$67.50		\$75.00	
Wessex	Antique Gold, Black Panel	\$52.50		\$60.00		\$67.50	
Set of 45	Hand Carved/Hand Fin./Seamless Cor. Frames	\$2400.00 (\$2835.00 value)					

Credit Card Information (check one)

Visa
 MasterCard
 Amex

Name on Card: _____
 Card Number: _____
 Exp. Date: _____

Gold Sponsor

Framer's Inventory

Mary Murray
800.543.2467

*Thank You for Your Support of the Evergreen Picture Framers Guild
4th Annual Educational Weekend & Awards Banquet*

Gold Sponsor

Wizard International, Inc.

Harry Everard or Mike Bell
206.489.2036

*Thank You for Your Support of the Evergreen Picture Framers Guild
4th Annual Educational Weekend & Awards Banquet*

EPFG President's Letter: Upcoming EPFG Election

(continued from page 1) PPFA has not met their financial responsibilities to the Chapter. Luckily, EPFG doesn't rely on PPFA for funding. The dues are only a part of our income: education and the newsletter supply 70% of our money. PPFA Chapter Leaders' training? This amounts to one day per year for as many members as the Chapter can afford to send to the seminar. This usually amounts to over \$500/person for airfare alone. We can get better training at home for less money if we want it.

What about EPFG responsibilities to PPFA? Just as bad a record as PPFA's, I'm afraid. We rarely support PPFA in its endeavors and are often critical of their favorite projects. The Art and Framing Council is a perfect example. We fought against it and lost. Now it is probably one of the few good things coming out of PPFA. EPFG has always accepted outside membership with the one restriction: that they were not allowed voting rights (temporarily suspended for this voting). This is in direct opposition to PPFA policy. It is a situation which will have to be resolved if we decide to stay with PPFA.

Over the years we have asked for many things for the Chapter from PPFA: newsletter articles, meeting topics, educational kits for meetings, a library (we bought our own). We have received none of these things.

PPFA is an organization of and for individuals, it is not set up for nor know how to support nor deal with chapters. This is an important point. There is no advantage for a "group" to belong to PPFA. Of course, until recent financial difficulties, there was no disadvantage either. So back to the original question: what will the effect on EPFG be if we vote ourselves out of PPFA? Since neither of us are fulfilling our part of the bargain anyway it doesn't seem to me to matter either way! There will be little change in EPFG and how we do things. We'll still have the newsletter, the monthly meetings, the education, the banquet and all the other things we normally have (none of which are supported by PPFA). The only difference to you is that the dues (\$40) will go directly to EPFG as they did before. If you wish to still be a member of PPFA you will of course have to pay their dues (\$125 for now) to them separately.

Yes, we can stand alone. We have done so for years! Do we want to? That is for you to decide. If we leave PPFA we have no way to influence the changes PPFA is considering. We can't work with them to improve what they offer for the individual and the chapters. However, if we don't belong and they do fail, they won't be able to suck us down too. Tough choice. Please vote.

— Franklin Larson, EPFG President

HARTUNG GLASS INDUSTRIES

- ◆ Complete line of Acrylics; Clear, Non-Glare & UV.
- ◆ We carry Tru-View, Sandel & Crystalview
- ◆ Specializing in beveled mirrors for framing.
- ◆ Next day delivery from Everett to Tacoma.
- ◆ Over 20 years experience with picture framers.
- ◆ Call us and have a Customer Service Representative specializing in your needs help you.



17830 West Valley Highway, Seattle, WA 98188
 (206)656-2626, (800)552-2227, FAX (206)656-2601

Bronze Sponsor

**Minuteman Press
of Issaquah**

Carl Peterson
425.391.4950

*Thank You for Your Support of the
Evergreen Picture Framers Guild
4th Annual Educational Weekend & Banquet*

Bronze Sponsor

Art Laminators

206.883.1780

*Thank You for Your Support of the
Evergreen Picture Framers Guild
4th Annual Educational Weekend & Banquet*

Bronze Sponsor

Studio Moulding

Marty Cohl & Joe Huber
206.656.2940

*Thank You for Your Support of the
Evergreen Picture Framers Guild
4th Annual Educational Weekend & Banquet*

Bronze Sponsor

**National Glass
Industries, Inc.**

Jeff Williams
800.521.7061

*Thank You for Your Support of the
Evergreen Picture Framers Guild
4th Annual Educational Weekend & Banquet*

Bronze Sponsor

**Hartung Glass
Industries**

Jack Mergens
206.656.2626

*Thank You for Your Support of the
Evergreen Picture Framers Guild
4th Annual Educational Weekend & Banquet*

Bronze Sponsor

FERENSOFT

John Ferens, CPF
206.282.1775

*Thank You for Your Support of the
Evergreen Picture Framers Guild
4th Annual Educational Weekend & Banquet*

*Brange Sponsor***Nurre Caxton**

Pamela Neal
800.255.1942 ext.4011

*Thank You for Your Support of the
Evergreen Picture Framers Guild
4th Annual Educational Weekend & Banquet*

June Meeting Notes**"Photo Handling and Restoration" a real eye-opener**

The June meeting, held at Studio Moulding in Kent, was attended by about 30 members and guests. The presentation by Alan Lamb on restoration of photographs was a continuation of the series of his super programs on photos, photography, and the proper techniques for handling and framing them. Many samples of photos, ranging from early daguerreotypes to modern computer generated images, were available in "before, during, and after" states of restoration.

Alan has launched into the field of digital imaging and restoration with a passion that characterizes all of his work, and the prowess he has gained is worthy of note. For those of us who were not familiar with what can be done to clean up damaged images, the program was a real eye-opener. For those of us who plan to call on a restorer, be aware that the services are not cheap!

For further details, and for information in order to refer customers in need of photo restoration, please contact Alan at Lamb Cottage Galleries.

A special thanks (again) to Marty and all the folks at Studio for their support of the Guild in hosting the meeting and providing the pizza, veggies, dip, drinks, etc.

We would like to apologize, however, for late publication of the Newsletter announcing the details.

EPFG LIBRARY

The EPFG library resources are available to members simply for the asking! To arrange pickup, or to pick them up as a monthly meeting, contact the EPFG Librarian, Allan Lamb, CPF, Lamb Cottage Gallery, Lynnwood, (206) 776-1911.

Check out the new library additions: books and videos on gilding, plus a set of basic gilding tools.

Books:

- Framers book of techniques and materials
- Framers guide to Japanese papers
- Picture Framing - Kistler I
- Mat Cutting - Kistler II
- Needlework - Kistler III
- Business Forms
- Conservation Framing
- Easy to build object box
- Frames & framing
- PPFA GUILD: Guidelines for framing works of art on paper

- PPFA GUILD: Guidelines for framing works of art on canvas

- Mounting, lamination, and texturizing
- Matting & hinging
- Marbling
- Art of showing art
- Beginners guide to faux finishes
- Guerrilla marketing
- How to care for works of art
- How to sell framing
- Life of a photo
- The gilder's manual
- Practical gilding

Videos:

- Traditional gilding
- Basics of matcutting/decorating
- Basics of picture framing
- Color selection in matting
- Conservation framing - Bowen
- Framing needlework
- French mats and inlaid mats
- Conservation framing needleart
- Conservation framing - Kistler
- Recognizing Graphic Art Techniques - FACTS
- Gilding Tools: gilder's pad, tip, and knife

PPFA in Financial Trouble

The rumors, the facts, and what you could do to help

Recently there have been an abundance of rumors about PPFA's shaky financial status. Recently a letter clarifying some of these problems was sent to the Chapter Presidents from the new PPFA Executive Director, Julie Freeman. In 1995 PPFA showed an increase in revenues and showed a profit — not enough to cover the previous several years of deficit, but it was encouraging.

In the unaudited financial statement for 1996 PPFA shows a deficit of \$140,000. How did this happen? PPFA's revenues fell short in all areas except education. The largest losses occurred in the convention area. Instead of generating a combined income of \$250,000 as budgeted, the income for the Toronto and Las Vegas shows was only \$86,000, a \$164,000 shortfall. This was a major blow to PPFA finances.

Another area causing concern is the cost of servicing members. Currently it costs \$125, not including chapter rebates, to provide direct services for retail members. New members cost an additional \$30 for the member manual and sales commission for the recruiting staff. This leaves a shortfall of about \$35 average per member. In past years this shortage was normally made up for by the convention and education profits. This is no longer so. PPFA has made several changes in the past few months to counteract the deficit situation.

The first step was to put the headquarters building up for sale. This happened in April, and they have already signed a contract for it. The sale should be completed in early August. Part of the contract allows the staff to continue occupying part of the building at a rental rate of half what a comparable office would cost. The equity in the building will go to repay some of the old debts.

Another step they have taken is to reduce staff by one-third, eliminating six positions, including two managers. Cutting PPFA contributions to employees' health insurance and slashing other operating costs has reduced the expenses for the remainder of the year by \$100,000. Since the amount of work has not been reduced, Julie is working with two management consultants to determine how to make PPFA more profitable and efficient while still providing members with quality services.

Unfortunately, these steps are not enough. PPFA needs \$100,000 by August 1st to cover payroll, basic expenses, newsletters, and postage for the Who's Who and For Members Only. Sales projections show only \$60,000 coming in by then so PPFA is asking for our help. The Board of PPFA is asking for a one-time voluntary special assessment of \$25 from each of its retail members. They will also be making an appeal to their supplier members. Julie and the Board have analyzed the mistakes made in the past and feel they know how to correct them. If each member makes a small contribution, PPFA can continue to provide education, certification, technical assistance, and cost-saving business programs.

If you believe in PPFA and what they are trying to accomplish, \$25 is a small price to pay. The small contribution will allow PPFA to move forward while continuing to provide you with all the services it has in the past. Julie asks for your trust and contribution, and pledges to manage an organization that offers meaningful benefits to all its members.

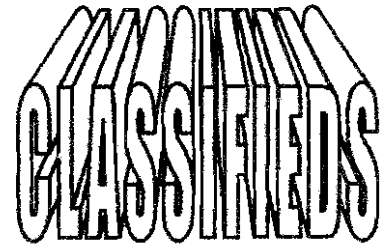

WANTED: SHOP MANAGER. High % Profit Sharing Plan in Capitol Hill - Broadway area (Seattle) frame shop & gallery. Shop needs an experienced person to run, oversee all phases of shop. This is a great career opportunity for the right person. No cap on your salary! Plus a written guaranteed signed contract will be given. Possible medical coverage. Send resume to: BFS, PO Box 4335 Seattle, WA 98104.

FOR SALE: Dry mount press (26" x 32") \$500, Stanley frame vise \$75. Contact Lou @ 206-621-0200.

FOR SALE: Art Gallery and Custom Frame Shop located in a prosperous bedroom community of Seattle. Mt. Rainier in your back yard and 2200 sq. feet of gallery and workshop, plus loft space. Located in a historic brick building. Well-established 15-year business with loyal customer base. Annual sales 120K. Fully-equipped frame shop includes computer and framing software. Owners retiring. (360) 825-5175.

A PERFECT OPPORTUNITY to expand or to start your own business. Located on a busy street in downtown Seattle Denny Regrade area. This store is the place for the custom picture framer. Fully-equipped plus some inventory. Lots of supplies. Has corporate clientele and steady repeat and walk-in business. Profitable. Very low rent. 864 sq. feet. 5 year lease w/ option. \$20K. Call (206) 441-6603.

HELP WANTED-2 POSITIONS. Available immediately. Delivery Driver and Customer Service at Seattle Framing Supply Warehouse. Please call Cindy, 292-9664, for more information, or fax resume to 624-9343.

Same Day Service
Jayeness Moulding Co.

Wholesale Picture Frame Supplies

2928 4th Ave S • Seattle, WA 98134
206-292-9664
800-423-6287

 **VICTOR MOULDING CO.**
977 66TH AVENUE, P.O. BOX 2206
OAKLAND, CA 94621 • 415-430-6400

WHOLESALE PICTURE FRAME SUPPLIES

CHUCK BIGFORD
SALES REPRESENTATIVE

(206) 481-2555

1-800-366-8428
1-415-430-8588 FAX

MESSAGE CENTER
1-800-359-2829
EXT 3715

 **TRU VUE MUSEUM GLASS™**

The ultimate in anti-reflective technology plus UV-protection.

- Lowest reflection rating available
- Highest brightness and contrast levels
- Greater clarity for true color transmission
- Edge-to-edge coating- less product waste, shorter cutting time
- Blocks 97% of UV light in the 300-380 nm range
- Cuts like regular glass
- No special handling procedures or cleaners needed

For additional product information on Tru Vue Museum Glass, please call the Framers Helpline

8 0 0 . 2 8 2 . 8 7 8 8

 **STUDIO MOULDING**

ORDER: (800) 262-4174
FAX: (206) 656-9125
LOCAL: (206) 656-2940

8214-B SOUTH 192nd ST., KENT WA 98032

- 5 chops: 5% Discount + Free Freight
- 10 chops: 10% Discount + Free Freight
- Length: Quantity Discount Available
- Routering Service **Joseph Huber**
Sales Representative

 **PACIFIC FRAMING SUPPLY**

695 Edgewater St. N.W.
Salem, Oregon 97304
Phone: 1-800-872-4445
FAX: 1-503-363-7273

21828 87th Ave. S.E., Suite B
Woodinville, WA 98072
Phone: 1-800-292-3202
FAX: 1-206-486-4978

**Colorful, Creative,
Pure & Strong...**

 **Crescent Rag Mat**
100% Cotton Museum Board

The choice of Artists & Picture Framing Professionals.
for archival and conservation matting.
Acid-free and lignin-free.

Send in your business card to receive
your FREE Rag Mat Booklet (RM-100).

Crescent Cardboard Company 100 W. Willow Road, Wheeling, IL 60090 U.S.A.

NURRE CAXTON

 **PAMELA NEAL**
Sales Representative
Washington, Wyoming, Montana
Oregon, Idaho

800-255-1942, press 6, ext. 4011 voice mail
800-377-3300 fax
800-910-8966 pager

 **ARQUATTI®**

Jeff Schuffman
Sales Representative

1433 W. Frankford Rd. #100 Carrollton, Texas 75007
972-466-0721 • 972-466-3662 Fax
800-527-0421 • 800-817-0524 Fax
Ext. 882

EPFG Picnic

Where: Magnuson Park (Shelter #1 on the shore, south of the boat ramp)

When: Sunday, August 3rd.

Directions: From Interstate 5 in Seattle.

Northbound I-5: Take the NE 65th Street exit. Go straight until you come to NE 65th Street. Turn right onto NE 65th.

Southbound I-5: Take the NE 71st Street exit. Turn left crossing the freeway. Turn right onto Roosevelt Way NE. Look for NE 65th Street and turn left onto it.

Follow NE 65th Street to Princeton Way NE. Make a right turn onto Princeton Way NE. Follow the winding road back to NE 65th Street. NE 65th Street will go straight into the park entrance.

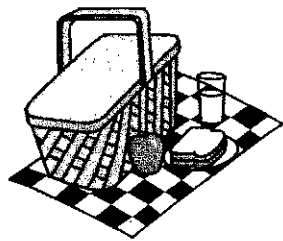

EPFG Membership Vote

continued from page 1

to remedy the situation, the Board of EPFG had already initiated action to place the issue before the membership to decide. The ballots contain statements supporting severing direct ties with PPFA, statements for remaining a chapter, rebuttal statements, and a post-paid ballot card to be returned to the Secretary. The statements were written by members of the Guild based on their knowledge of the past problems and information provided by PPFA. Ballots are to be returned by July 15, 1997. If you have any questions concerning this matter, contact Frank Larson, President, at (425) 428-0549. Eligible voters are those whose dues are paid as of May 1997. Please vote; help decide the future of your organization.

The outcome of the vote is not expected to drastically change the publication schedule of our monthly Newsletter or the monthly meetings. Stay tuned for further developments and late breaking results!

Software suite for Windows, DOS & OS/2
 New Version! Galleries & Frame shops User Friendly!

FERENSOFT TRIO!

- Art
- Customers
- Framing

Business management suite includes original **FRAMESHOP™** software. See why people are switching to **FERENSOFT!**
 Seattle 206-282-1775.
 Created by *Decor* columnist John Ferens, CPF.



Extreme Value



THE WILLIAMSON CO.
 FINE MOULDINGS & FRAMES

Manufacturer & Distributor
 OF QUALITY PICTURE FRAME MOULDING
 AND READY MADE FRAMES

For more information, call
Donna Gluyas
 Western Region Sales Manager
 1-800-851-2467

Archive Mattboard • Burnich & Designer Moulding • Clark Moulding
 Foamcore • Miller Mattboard • Piedmont Moulding
 TriVue Glass • Williamson Moulding

METAL FRAMES ART



6010 EAST ALKI WAREHOUSE #5 SPOKANE, WASHINGTON 99212
 PHONE 800 344-7329 509 535-3440 FAX 800 344-5003 509 535-3466

SEATTLE, WA 98133



THE ART DOCTOR
 Restoration of Oil Paintings, Japanese Screens,
 Art on Paper, Art Objects

NANCY G. WHITE (206) 783-9160
 Restorer By Appointment

July Meeting Topic

John M. Ferens to present
 "No-Hype Computing"

A long time chapter member, John M. Ferens, CPF, has been a picture framer and is now an industry supplier of gallery and frame shop software with his Seattle company, FerensSoft. As a contributing editor for Decor magazine, John has written over 70 pieces on computers, including the popular "Computer-Ease" monthly column.

Someday soon, every shop will use a computer. In the mean time, using computers can give you a huge advantage over non-computer-using competitors. John's topic, "No-Hype Computing" will focus on helping you understand the computer tools you can use right now to move your business into the 21st century.

The meeting is on July 8 at 6:30 p.m. at Jayeness Moulding, 2928 - 4th Ave S., Seattle, 206-292-9664.

PORTICO.

Eight uniquely crafted mouldings inspired from the fresco walls of European villas and the worn, layered look of painted antique furniture.

For more information on new Portico and other Larson-Juhl framing products call:
 (800) 438-5031

or contact your Larson-Juhl sales representative
 by calling (800) 223-0307

Stephen Dean - ext. 454 Paul Anderson - ext. 456
 Joe Garitone - ext. 455

LARSON · JUHL

ADDING ARTISTRY TO ART
 WARMTH TO LIVING

Evergreen Picture Framers Guild

Officers and Board of Directors

President

Frank Larson, CPF
 Larson Fine Art Services
 425.482.0549

John Ferens, CPF
 Ferenssoft
 206.282.1775

Vice President

Jeff Schuffman
 Jeffery Schuffman & Assoc.
 206.223.1810

Alan Lamb, CPF
 Lamb Cottage Gallery
 206.776.1911

Treasurer

Paul Knoop, CPF
 The Frame Makers
 253.564.2320

Steve Dean
 Larson-Juhl
 206.433.6002

Secretary

Donna Rickman, CPF
 Finishing Touches
 425.338.0932

Joe Huber
 Studio Moulding
 206.656.2940

Past President

Paul Miller, CPF
 Raindrops Gallery
 206.528.2832

Deborah Pittman, CPF
 Fast Frames, Tacoma
 253.471.9210

Newsletter Coordinator

Tim Taricco
 Ph. 425.827.6951
 Fx. 206.781.8590
 frameplus@msn.com





FRAMERS' INVENTORY

Specializing in the Fine Art of Service.

STILL GROWING!

WOOD MOULDINGS
 ARQUATI, BAY, FRAMERS' INVENTORY,
 LA MARCHE, MAX, PIEDMONT, SENELAR,
 WILLIAMSON

METAL MOULDING
 DESIGNER & NIELSON

MATBOARD
 BAINBRIGE, CRESCENT, MILLER

C&H AND FLETCHER FRAMING EQUIPMENT
 SEAL MOUNTING EQUIPMENT.

5000 S.E. 18TH AVENUE, PORTLAND, OR. 97202
 TOLL FREE# 1(800)543-2467

1997 Calendar of Events

July 8 6:30 pm

Location: Jayeness Moulding, 2928 - 4th Ave S.,
Seattle, 206-292-9664

Topic: Framing Software

July 29 6:30 pm

EPFG Board Meeting

August 3 (Sunday)

EPFG Picnic

Magnuson Park (the old Sand Point Navy base)
shelter #1, south of the boat ramp

September 9 7:30 pm

Topic: Shop and Gallery Lighting

September 23 6:30 pm

EPFG Board Meeting

October 14 7:30 pm

Topic: Color Trends for 1998

November 12 7:30 pm

Topic: Holiday Tricks & Treats

November 25 6:30 pm

EPFG Board Meeting



c/o Paul Knoop, CPF, Treasurer
6724 W. 19th Street
University Place, WA 98466-5527

