

# PICTURE FRAMING, IT'S NOW SERIOUS BUSINESS

By Tim Taricco, Colorplak

In the past, the picture framing industry has largely been a mom-and-pop single-store mentality. Today everything is changing and if you don't change with the trend, you won't be around to see the future. That may seem like a bold statement, but it is true. If you look around at the changing marketplace, you will notice that multi-store picture framing chains are taking over most of the neighborhoods.

In the Pacific Northwest, we currently have a large percentage of "mom-and-pop" stores, a few local chain stores, the big national craft stores and the independently owned franchise stores. That list of competition is nothing compared to what is coming. Picture framing is going the same way as the office supply business has gone, big time. Fifteen years ago, did you know about Office Depot and Staples in the Pacific Northwest?

In the coming years, the Pacific Northwest is going to be introduced to Aaron Brothers and Corners Custom Framing. Both stores will bring big marketing budgets to our region. This will mean stiff competition for "mom-and-pop" frame shops and the local chain stores.

*(Continued on page 3)*

## PRESIDENT'S LETTER

By Paul Knoop, the framemakers Tacoma



What an exciting Spring Festival!! Over 100 framers, vendors, and family members attended our 6th annual educational programs, framing competition, and banquet. The classes were all very well attended and professionally done; the 12 entries in the competition were all eye-catching, and the dinner speaker, Dennis Tilley, was exceptional. My personal thanks (again) to all those who attended and especially to those who worked so hard to make it all happen. If you have any comments concerning the day's activities, please be sure and let us know-your

*(Continued on page 6)*

### INSIDE THIS ISSUE

CLASSIFIED ADS	5
EDUCATION FESTIVAL HIGHLIGHTS	8
1999 PRICING FOR PROFIT SURVEY	INSIDE
EVENTS CALENDAR	BACK



April 1999

Newsletter Cost: free to EPFG members, \$1.00 for non-members

Serving Alaska & Washington

## MESSAGE BOARD

### GOING TO THE FRYE ART MUSEUM

Have you ever wondered how museums handle, frame and store their art treasures? Are you curious about how a museum protects their art collection while it is on display? Do you know what UHU is? And just what do conservators do with that stuff, anyway? Ann Jespersen and David Anderson of the Frye Art Museum are offering us the opportunity to visit behind the scenes once again. This special tour is available only on Thursday, April 15, at 6 PM. The tour is limited to 20 people. Call Terry Scidmore to reserve your space. 206-433-1145

### THERE IS A MEETING NEAR YOU THIS MONTH

**Bellingham** - April 13th

**Olympia** - April 13th

**Yakima** - April 27th



## HOW TO CONTACT US

### Membership Dues, Advertising Payments:

Kioski Toda, EPFG Treasurer  
3058 Issaquah-Pine Lake Road  
Issaquah, WA 98027  
425.557.5494

### Change of Address:

Nancy Chapman  
15209 263 Ave. SE  
Issaquah, WA 98027  
425.392.7334

For changes of address please include old and new address information.

### Classified Ad Copy, Display Ad Artwork:

Tim Taricco  
P.O. Box 411  
Redmond, WA 98073  
frameguy@myframeshop.com

**Classified ads**  
Free for EPFG members, \$10 for non-members

**Display Ad Artwork**  
Digital artwork is requested. Submit via e-mail or on PC disk.

**Publishing Deadline**  
20th of the month prior to distribution

## 1999 EPFG Officers

### President

Paul Knoop, CPF  
*the framemakers*  
253.564.2320  
pknoop@earthlink.net

### Vice President

Donna Rickman, CPF  
*Finishing Touches*  
425.338.0932  
rickman@aol.com

### Treasurer

Kiyoshi Toda, CPF  
*Accent On Framing*  
425.557.5494

### Secretary

Terry Scidmore, CPF  
*The Mitered Corner*  
206.433.1145

### Board Of Directors

Joe Garitone, CPF  
*Larson-Juhl*  
800.223.0307 x455

Joe Huber  
*Studio Moulding*  
800.262.4174 x217

Ben Edwards  
*Framers' Inventory*  
888.562.2440 x449

Ray Miles  
*National Glass*  
800.521.7061

### Past President

Frank Larson, CPF  
*Larson Fine Art Services*  
425.482.0549

The EPFG Newsletter is published monthly by Tim Taricco.  
**Mailing Address:** P. O. Box 411 - Redmond, Washington 98073-0411. **Phone:** (425) 885-9730 **E-mail:** frameguy@myframeshop.com **Web Site:** http://www.myframeshop.com/tradeonly/. Newsletter Design ©1999 T. M. Taricco and Newsletter Content ©1999 Evergreen Picture Framers Guild. All rights reserved. Do not duplicate or redistribute in any form.

**Need Training for New Employees?**

**SEE WHAT YOUR DOLLAR CAN DO IN CANADA**

**The Canadian Picture Framer's School**  
#1, 20678 Duncan Way  
Langley, B.C.

providing excellent thorough instruction in picture framing for over 10 years. Phone or fax for more info:  
Ph: 604-533-5328  
Fax: 604-533-9680

**STUDIO MOULDING**

8214-B South 192nd St., Kent, WA 98032

**FREE FREIGHT**  
On all orders over \$100.00 in OR and WA

**JOE HUBER**  
Orders: (800) 262-4174  
Voice Mail Ext: 217  
Fax: (888) 423-1814

**CORONA**  
1150 Industry Drive Tukwila, WA 98188  
Division of RCI, Inc.

The choice of professionals, CORONA Cold & Hot/Cold Vacuum presses. Complete mounting/laminating supplies. Originators of BERTO and Corona Hot/Cold Unimount adhesives...the industry mainstays for over 20 years. 'The Mounting Specialists'.

Suppliers to the Picture Framing Industry for over 30 years

206.575.2727 Fax: 206.575.2667



**Jeff Schuffman**  
Sales Representative

1433 W. Frankford Rd. #100 Carrollton, Texas 75007  
972-466-0721 • 972-466-3662 Fax  
800-527-0421 • 800-817-0524 Fax  
Ext. 882



2928 4th Ave S • Seattle, WA 98134  
Wholesale Picture Frame Supplies  
206-292-9664  
800-423-6287

Software Suite for Windows 95 and earlier  
Galleries & Frame shops Networking User Friendly!

**FERENSOFT**  
**TRIO!**

- Art
- Customers
- Framing

Point of Sale and Business Management suite with optional WIZARD™ mat cutter link. See why people are switching to FS TRIO! Seattle 206-282-1775.

## FEBRUARY IN REVIEW

CONTINUED

*(Continued from page 1)*

I am writing this article so we all can be informed and will have time to get prepared. Corners Custom Framing (formerly Frame King Express) currently has 24 stores in San Francisco and Boston. This year they will open 45 new stores in New York City, New England and San Francisco. The following years plan for 25 to 50 stores in each of the following regions: Baltimore/Washington, Chicago, Atlanta, Seattle/Portland.

I know your next question is, "How can I get ready to compete?" My first answer is to join the Evergreen Picture Framers Guild and attend as many meetings as you can. Besides learning new framing techniques, our meetings involve discussing business issues that we all face.

My second answer to that questions is, get organized and educated. To do both those things, you need a computer. If you are running your frame shop without a computer, you are doing business at a disadvantage to your competition. Computers are cheap these days. You can get a complete system, with a printer for only \$800.

Once you've got your computer, you need some good software to help you get organized and you need Internet access to get educated. Now you are probably asking, "How much will the software and Internet Access cost." You can get both for FREE, but remember, you get what you pay for.

Get your computer and check out the resources below to help yourself get ready for the new competition coming to town.

**FREE Framing Software** -- <http://thegrumble.com>

**FREE Internet Access** -- <http://netzero.com>

**TRUVUE GLASS**  
FOR EVERY FRAMING NEED

<p><b>PREMIUM SERIES GLASS</b></p> <ul style="list-style-type: none"> <li>• PREMIUM CLEAR™</li> <li>• REFLECTION CONTROL™</li> <li>• AR™ REFLECTIVE FREE</li> </ul>	<p><b>CONSERVATION SERIES GLASS</b></p> <ul style="list-style-type: none"> <li>• CONSERVATION CLEAR™</li> <li>• CONSERVATION REFLECTION CONTROL™</li> <li>• MUSEUM GLASS™</li> </ul>
---	--

1-800-368-5577

**Supporting the EPFG for over 6 Years**

We are the original art laminator giving you the best service and quality in the industry.

**800-305-1953**

**Tim Taricco**  
425-885-9730



# PRADO™

*Seven golden mouldings reminiscent of regal antiquity.*

For more information on Prado and other Larson-Juhl framing products call:  
(216) 433-6002, (800) 627-1500 or (800) 438-5031

or contact your Larson-Juhl sales representative

Voice Mail: 800-223-0307

Stephen Dean - ext. 454 • Paul Anderson - ext. 456 • Joe Garitone - ext. 455

## LARSON · JUHL

ADDING ARTISTRY TO ART  
WARMTH TO LIVING

# NATIONAL GLASS

17030 WOODINVILLE-REDMOND ROAD, WOODINVILLE, WA. 98072

**QUALITY PRODUCTS AND EXCELLENT SERVICE!** NATIONAL GLASS  
INVENTORIES THE LARGEST SELECTION OF PICTURE FRAMING GLASS IN THE PACIFIC  
NORTHWEST.



NATIONAL GLASS

**TRU VUE AND SANDEL PREMIUM, REFLECTION CONTROL, SATINVIEW, CONSERVATION  
SERIES GLASS, IMAGE PERFECT, DENGLAS, AND CRYSTALVIEW.**

**Now Available - AR Glass & Museum Glass!**

**ALSO AVAILABLE: *FOAM-X*, MIRROR AND ACRYLICS**

**EVERYTHING YOU NEED AND *FREE DELIVERY* ARE ONLY A PHONE CALL AWAY!**

(425) 488-8126

1 (800) 521-7061

fax (425) 488-3712



SEATTLE, WA 98133



**THE ART DOCTOR**  
Restoration of Oil Paintings, Japanese Screens,  
Art on Paper, Art Objects

**NANCY G. WHITE** (206) 783-9160  
Restorer By Appointment

## CLASSIFIED ADS

If you have something to sell, do it here!!! Classified ads are FREE for EPFG members and \$10 for non-members. This is just another benefit your \$40 membership fee gives you.

- **FRAME SHOP** in Seattle for sale. Contact Mike at 206/634-1558 for details.
- **FOR SALE:** Phaedra measuring system and chop saw with spare blades, wood and metal. Like new, and little use asking \$650.00. Contact Geraldine 253/566-9037 for details.
- **WANTED:** Mat cutter, 48" with measuring stops, etc. Contact Lisa 253/274-1683 for details.
- **EQUIPMENT FOR SALE:** 40 x 60 Corona Vacuum Press, complete \$600. C&H 60" Pro Wall Cutter, like new \$800. Fletcher 2100 40" mat cutter w/ production stops, \$600. Eight department cash register, new \$80. Zon Jr. XL credit card terminal, \$150. To view the equipment, call Philip at 206/281-0054.
- **MAT CUTTER FOR SALE:** C&H 60" mat cutter with measuring stops and squaring arm, \$650. Contact Lisa at 253/565-3711.
- **THUMBNAILER FOR SALE:** Includes router bits and inserts, \$500. Contact Lisa at 253/565-3711.
- **SHRINK WRAPPER FOR SALE:** Traco 40" Super Sealer with heat gun, \$150. Contact Lisa at 253/565-3711.

Williamson • TruVue Glass/Miller Matboard • Clark • Designer Wood & Metal  
Piedmont • Colonial • Burnich • Foamcore

**Continuing the Colonial Tradition**  
2 NEW PROFILES IN OAK • 8 COLORS

Free Sample! Call for Details

METAL FRAMES ART



6010 EAST ALKI WAREHOUSE #2 SPokane WASHINGTON 99212  
PHONE: 800.344.7276 509.323.1140 FAX: 800.344.3073 509.535.3460



**Pacific Framing Supply**  
*"Serving all of your framing needs"*

**Brad Airhart & John Cave**

Salem, OR 97304 Woodinville, WA 98072  
Phone: 1-800-872-4445 Phone: 1-800-292-3202  
FAX: 1-503-363-7273 FAX: 1-206-486-4978

**Colorful, Creative,  
Pure & Strong...**



**Crescent Rag Mat**  
**100% Cotton Museum Board**  
The choice of Artists & Picture Framing Professionals,  
for archival and conservation matting.  
Acid-free and lignin-free.

Send in your business card to receive  
your FREE Rag Mat Booklet (RM-100).

Crescent Cardboard Company 100 W. Willow Road, Wheeling, IL 60090 U.S.A.

*Fabric & Liners*

*The Softer Side of Framing*  
Hundreds of colors and textures --- Exclusive pH Neutral Fabrics



**Fabrics for Framers**  
Dial Toll-Free (888) F.FABRIX (332-2749)



**FI FRAMERS' INVENTORY**

**NOW OPEN IN SEATTLE!**

**WOOD MOULDING**  
Arquati, Bay, Framers' Inventory,  
LaMarche, Max, Roma, Williamson

**METAL MOULDING**  
Nielsen

**MATBOARD**  
Bainbridge, Crescent, Tru Vue

**GLASS & FOAMBOARD**  
True Vue, Sandel,  
Bienfang, Bainbridge

**EQUIPMENT**  
C&H, Fletcher  
Seal Mounting

**SERVICE**  
Daily delivery in the  
Portland & Seattle Metro areas  
Will call open til 6:00 PM  
Overnight chop service

**FI**

4412 4TH AVENUE SOUTH, SEATTLE WA 98143  
5000 SE 18TH AVENUE, PORTLAND, OREGON 97202  
TOLL FREE(800)543-2467 FAX(503)238-3899

**VICTOR**  
MOULDING COMPANY

*Have You Seen?*

**Southern Comfort Line**  
**Hunt Club Line**  
**Impasto Line**  
**Tiburon Line**

IF YOU HAVEN'T, CALL YOUR SALES  
REPRESENTATIVE TODAY!

**1-800-359-2829**

**Chuck Bigford Ext. 3715**

**VM**  
3439 S.W. BOND  
PORTLAND, OREGON 97201  
*Jim Jillard - Branch Manager*

## PRESIDENT'S LETTER CONTINUED

*(Continued from page 1)*

feedback on this and all other aspects of the Guild's program is vital.

Well, as you probably know by now, our "Road Show" is taking off again this month, with programs in Bellingham, Yakima, Olympia, and a Frye Museum tour in Seattle. I know we will make some new friends, and hopefully gain some new members to the Guild who will contribute to the strength of our organization. If you can't make one of these meetings, yet would like information on a program, or have a question on framing, please don't hesitate to contact us. Remember, our purpose is to help each other and to improve the art of picture framing. Something we have not covered lately that you can help with? Let us know, and we will be happy to arrange for you to share your information with us at a meeting, or, how about just writing a short article for the Newsletter.

Pricing, a subject near and dear to all of us; you have an opportunity for input into this important area of business. Please take a few minutes to complete and return the pricing survey before April 15th. Your input is vital to getting a clear picture of how picture framing is priced in our regional area. Have you ever wondered how your prices compare to your neighbor's across town? Now is your opportunity to evaluate your costs and prices with other shops in the area. This survey has proven to be a subject of heated discussion in past years, and we will have numerous opportunities to review the various elements in the coming months, but we need your help.

*Paul Knoop*  
EPFG President

**NURRE CAXTON**  
FRAMES OF DISTINCTION

 *"We're Obsessed  
With Customer  
Satisfaction"*

**Pamela Neal**  
Sales Representative for  
Washington, Wyoming, Montana  
Oregon and Idaho

1-800-255-1942, press 6, ext. 4011  
for voice mail  
1-800-377-3300 fax  
1-800-910-8966 pager

We promise friendly, reliable service,  
same day chop service, free UPS  
for orders of 3 chops or more  
(wood and Nielsen metal combined)



**HARTUNG**  
GLASS INDUSTRIES

Hartung Glass was the first company in the Northwest Region to deliver to the Picture Framing Industry. We have been serving the Picture Framers in our area for over twenty years and offer the largest inventory of stock sheets in the Pacific Northwest. We feature all of the top manufacturers, including Sandel, Tru-Vue, and Cyro, with scheduled deliveries to most areas of Washington. We carry many types of framing glass, including:

- |                 |                    |
|-----------------|--------------------|
| Clear           | Sandel Superior    |
| Anti-Reflection | Sandel Crystalview |
| Non-Glare       | Tru-Vue & Sandel   |
| Conservation    | Tru-Vue            |
| Preservation    | Sandel             |
| Museum Glass    | Tru-Vue            |

Call today to schedule a delivery!

*Hartung now stocks  
3/16 mirror with 1" bevel for framing.  
Call our helpful customer Service Department today to place your order!*

425/656-2626  
800/551-2117

**Chances are you started out with a LOGAN Mat Cutter  
Have you seen what we've done lately?**

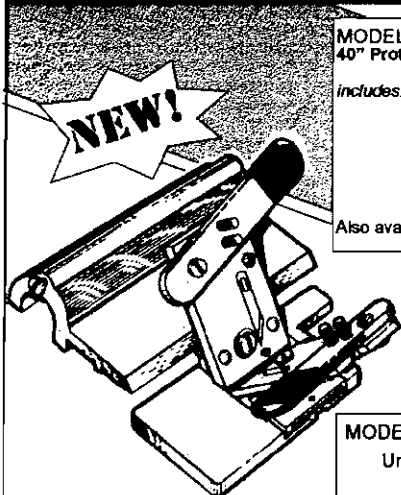

Model 705  
Logan  
V-Groover

**MODEL #650 Framers Edge MAT CUTTER**  
40" Professional Production Matcutter

- includes:
- Ergonomically designed Dual straight and Bevel cutting head
  - Production Stops
  - Parallel Mat Guide
  - Start and Stop Indicator for line to line cutting.
  - 27" Squaring Arm

**Suggested List Price \$599.95**

Also available in a 60" version MODEL #660 Framers Edge \$799.95

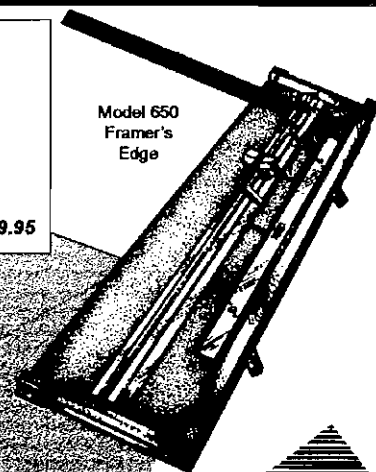

Model 650  
Framers  
Edge

**MODEL 705 LOGAN V-Groover** patented

Unique "push-pull" surface V-Groover that cuts beautiful V-Grooves on the surface of the matboard. Works entirely with stops provided for accurate V-Grooving in seconds with zero overcuts. Endless creative possibilities!!

**Suggested List Price \$125.00**

**MODEL 706 Universal V-Groover** patented

Works on professional mat cutters using a 5/8" thick cutting bar rod including Fletcher® and C&H® professional matcutters.

**Suggested List Price \$150.00**





GRAPHIC PRODUCTS, INC.  
1100 MOWEN STREET • WYALONDA, ILLINOIS 60084  
NATIONWIDE TOLL FREE 1-800/331-4222  
TOLL FREE FAX 800/331-4329

See us at <http://www.artproducts.com>  
E-MAIL: [Logan-Graphic-Products@worldnet.att.net](mailto:Logan-Graphic-Products@worldnet.att.net)



Supporting the EPFG Education Festival Every Year!

**It's About Choices...**

 Crescent Regular Matboard, with the greatest array of colors, is the **right choice** for everyday do-it-yourself framing. Crescent Whitecore Basics, with its non-yellowing white core, is the **ideal choice** for the design requirements of today's contemporary decor. Crescent Rag Mat remains the **only choice** for conservation framing. With its naturally 100% acid- and lignin-free custom core,  is the premier choice for protecting precious works of art and irreplaceable memories.



We Give You The Right Choice!<sup>SM</sup>

<http://www.crescent-cardboard.com>

Crescent Cardboard Company, 100 West Willow Road, Wheeling, Illinois 60090, Tel. 1-847-537-3400, Fax 1-847-537-7153

**NATIONAL GLASS**

**TRUVUE GLASS**  
FOR EVERY FRAMING NEED

<p><b>PREMIUM SERIES GLASS</b></p> <ul style="list-style-type: none"> <li>• PREMIUM CLEAR*</li> <li>• REFLECTION CONTROL*</li> <li>• AR** REFLECTIVE FREE</li> </ul>	<p><b>CONSERVATION SERIES GLASS</b></p> <ul style="list-style-type: none"> <li>• CONSERVATION CLEAR*</li> <li>• CONSERVATION REFLECTION CONTROL*</li> <li>• MUSEUM GLASS*</li> </ul>
--	--

© 1999 TRUVUE GLASS  
\* 100% UV PROTECTION \*\* 99% REFLECTION

**First Place**



Finishing Touches, Mill Creek

**Second Place / Popular Choice**



Fast Frame Of Bellevue

**Third Place**

The Framemaker, Yakima





# New Pre-Covered Lip Liner

Ask about our  
Distributors Discount.

Expanded Liner Selection

## **Framing Fabrics & Moulding International**

is very happy to introduce **NEW LINERS**. With the recent expansion of our liner offerings, we are able to provide our customers with a complete liner selection, at very competitive prices. These seven new additions include a flat profile in two sizes, a bevel profile in two sizes and a scoop profile in three sizes, all with hand-finished lips of bright gold, antique gold and antique silver. These lip liners are available in four fabrics, 100% BELGIQUE Natural Linen; Union Blend of MANHASSET Natural and Oyster and Antique Satin MARQUIS Black.

## LIP FINISHES

Bright Gold ❖ Antique Gold ❖ Antique Silver

## FABRICS

Manhasset Natural ❖ Manhasset Oyster  
Belgique Natural ❖ Marquis Black

All are pre-covered. However, we are also able to meet most of your custom needs (*Custom Wraps*), just call and ask our Customer Service Department personnel. Upon request, we can cover our lip liners with any of the 500 fabrics we sell. A 50 ft. minimum applies to liners cut to 6 & 4 or 5 & 5 ft. lengths; a 100 ft. is required on liners in standard 10 ft. lengths.

These liners are in addition to the original thirty liner profiles we offer in Primed, Pre-covered and *Custom Wrapped* both in length and chop.

### FLAT

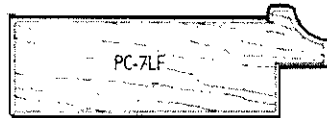
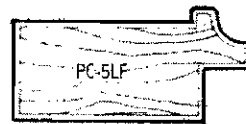

### BEVEL

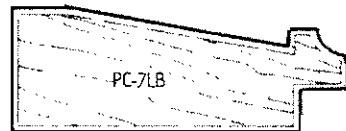

### SCOOP

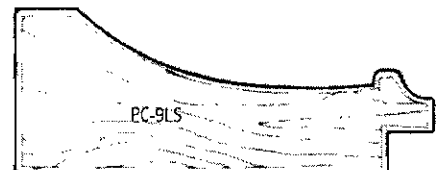
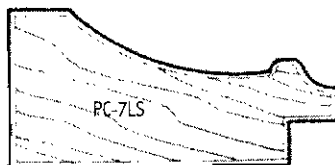
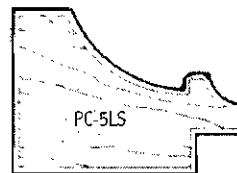

Shown Actual Size



## THE PRINT COMPETITION

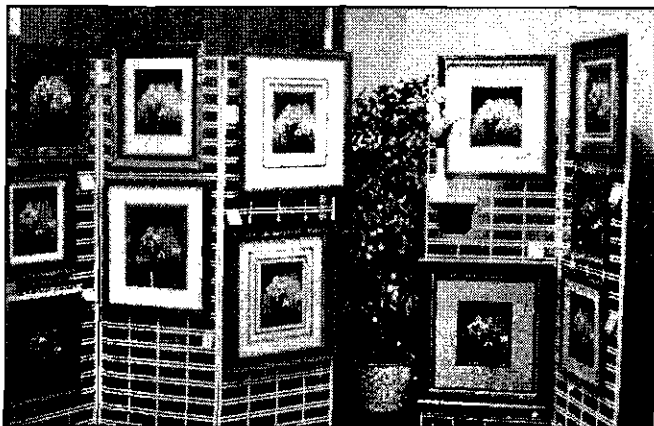

Thank you to all who contributed to the Print Competition at the Education Festival, it was a wonderful success! Half of the prints sold came back as finished pieces for the competition, a high percentage. If you attended the banquet and saw the entries, you know how interesting and diversified they were, no 2 were even similar, a credit to your creativity. The judges want the participants to know how difficult it was to judge them, each had great qualities. As shown by the ballots cast for Popular Choice, someone liked each of them the best!

*Fabric & Liners*

*The Softer Side of Framing*

Hundreds of colors and textures --- Exclusive pH Neutral Fabrics

*Frank's*

Fabrics for Framers

Dial Toll-Free (888) F.FABRIX (332-2749)

### LARSON JUHL

Software Suite for Windows 95 and earlier

Galleries & Frame shops   Networking   User Friendly!

**FERENSOFT**

**TRIO!**

- Art
- Customers
- Framing

Point of Sale and Business Management suite with optional WIZARD™ mat cutter link. See why people are switching to FS TRIO! Seattle 206-282-1775.

### CANADIAN PICTURE FRAMING SCHOOL



Still serving your glass needs after 75 years. Hartung Glass Industries is your reliable source for the best in service and supplies.



**HARTUNG**  
GLASS INDUSTRIES



For more information or to order Hartung's free Special Picture Framing Price Book, call our Framing Specialist, Jack Mergens.

★ 425-656-2626 or 800-552-2227 ★

# THE EDUCATION CLASSES



"Sold out! Bring in more chairs."

## NEILSEN & BAINBRIDGE

## DESIGNER MOULDING

## VICTOR MOULDING

More classes bring more framers out to the Education Festival.





# THE AWARDS BANQUET



Steve Dean wins Sales Representative of the Year

**“Larson Juhl sweeps the Awards Banquet!”**

Vendor of the Year

John wins Delivery Driver of the Year

Joy wins Customer Service Representative of the Year



**FRAMELESS FRAMING™**

Celebrating our sixth year of serving the art framing industry from beautiful downtown Kenmore.

A unique process for displaying art, maps, photos & much, much more...

7204 NE 175th Street, Suite A  
Kenmore, WA 98028  
425.487-6128 800.780-7095 FAX 425.487-2082

## FRAMERS' INVENTORY



2928 4th Ave S • Seattle, WA 98134  
Wholesale Picture Frame Supplies 206-292-9664  
800-423-6287



8214-B South 192nd St., Kent, WA 98032

**FREE FREIGHT**

On all orders over \$100.00 in OR and WA

JOE HUBER

Orders: (800) 262-4174  
Voice Mail Ext: 217  
Fax: (888) 423-1814

1999 EPFG Education Festival Sponsors

**April 1999**

**13th** – General Meeting – 7 PM  
*Art And Frame* – Bellingham  
Glazing & Beyond

**15th** – Field Trip – 6 PM  
*Frye Art Museum* – Seattle

**13th** – General Meeting – 7 PM  
*Olympia Framemakers* – Olympia  
Mounting Sumi & Rice Paper

**27th** – General Meeting – 7 PM  
*Framemaker* – Yakima  
Installations

**May 1999**

**11th** – General Meeting – 7 PM

*The Mitered Corner* – Seattle  
Pricing Round Table

**25th** – Board Meeting

**June 1999**

**8th** – General Meeting – 7 PM

*Rainy Day Frames* – Seattle  
Tricks of the Trade

**July 1999**

**13th** – General Meeting – 7 PM

*Lake City Picture Framing* –  
Seattle  
Fabric Mats

**27th** – Board Meeting

**August 1999**

Annual Picnic

**September 1999**

**14th** – General Meeting – 7 PM

*Larson Juhl* – Seattle

**28th** – Board Meeting

**October 1999**

**12th** – General Meeting – 7 PM

*Millennium Gallery* – Redmond



**UNIVERSAL**  
Framing Products

**Edgar Solares**  
Account Representative  
Telephone • 206-440-1547

9415 Telfair Avenue • Sun Valley CA 91352  
Telephone • 818-767-8700 • 800-668-3627



T. M. Taricco  
P. O. Box 411  
Redmond, Washington 98073-0411

ADDRESS CORRECTION REQUESTED

**ATTENTION: FRAME SHOP**

98193-2848 66



# 1999 PRICING FOR PROFIT SURVEY

THE BOARD OF EPFG IS DOING A PRICING SURVEY. We would appreciate you filling out this form and mailing it before April 15th. We will be running the results in the May or June issue of the EPFG Newsletter. We can only do this with your cooperation. All responses are confidential, in fact, we don't even ask your name. We need at least 40 responses to accurately calculate the averages. Please do not assume we will have enough without you. WE NEED YOUR INPUT!

	8 x 10	28 X 36	40 X 60
Regular Glass			
Conservation Clear Glass			
Plexiglas			
UV Plexiglas			
Fitting (Normal for Wood Frame)			
Single Archival Mat (Crescent 1550)			
Single Regular Mat (ie: C901)			
Dry Mount			
Spray Mount			
Wet Mount			
Conservation fee *			
Stretching Oils **			
Lacing needlework onto rag board			

\*Includes 4 ply rag mount board with the artwork hinged to it with japanese paper hinges and starch adhesive. ALSO includes a 4 ply rag window mat hinged to the mount board as recommended in PPGA Guidelines.

\*\*Includes stretcher bars.

This year we would like to ask some questions which have come up at several meetings.

What is the square footage of your store? \_\_\_\_\_, What is your rent (including NNN) \$\_\_\_\_\_/month

How long does it take to do your average frame job? \_\_\_\_\_; Average number of frames per week? \_\_\_\_\_

Do you have an automated mat cutter? Brand? \_\_\_\_\_

How long does it take to cut an average mat (including getting the mat out, sizing the outside, cutting the opening, handling the waste, changing the blade, and putting the cutoff away for future use? \_\_\_\_\_

How much do you pay for a 32x40 regular mat (Crescent 1027)? \$ \_\_\_\_\_

How many full time employees (not including yourself) in your shop? \_\_\_\_\_, part time employees? \_\_\_\_\_

What is your employee's average wage? New hire: \_\_\_\_\_ After one year of experience? \_\_\_\_\_; 2 years? \_\_\_\_\_  
3 years? \_\_\_\_\_ over 5 years? \_\_\_\_\_. What do you pay yourself? \_\_\_\_\_ per month.

Do you provide benefits for your full time employees? Health Ins? \_\_\_ Dental Ins? \_\_\_ Retirement? \_\_\_

Do you provide benefits for your part time employees? Health Ins? \_\_\_ Dental Ins? \_\_\_ Retirement? \_\_\_

**Please price these**

**packages:**

Frame Size: 16 X 20

Frame: Nielson 05 Silver

Glazing: Regular Glass

Mat: 1 Cons. Mat

(Crescent 1610) \$ \_\_\_\_\_

Frame Size: 28 X 36

Frame: Larson Juhl #559WS

Glazing: Cons. Clear Glass

Mat: Hand wrapped Linen mat with

Larson Juhl fillet

#159WS in opening. \$ \_\_\_\_\_

The Board of EPFG hopes that this survey will help make your business more profitable. If you have any questions you would like to see on next year's survey please jot it down anywhere on this form.

Please take a few minutes to answer the questions  
on the other side of this form.

**WE DO NOT WANT YOU TO SIGN THIS FORM.**

The survey printed in DECOR is based on a small selected group of frame shops across the country and we know the information may vary greatly from area to area. As a service for our members EPFG is doing its own pricing survey. Upon your return we will compile the data and publish the information on low, high and average prices in our area. We appreciate your cooperation.

---

FOLD AND TAPE OR STAPLE

PLACE POSTAGE HERE
--------------------------

**SEND TO:**  
**Evergreen Picture Framers' Guild**  
**C/O Frank Larson**  
**20611 Both.-Evert. Hwy.**  
**Unit 289**  
**Bothell, WA 98012**

---

FOLD AND TAPE OR STAPLE