

# SPRING FESTIVAL SPECIAL EDITION

## OUR PRESIDENT'S PEN

BY PAUL KNOOP, EPFG PRESIDENT



Please take a second to look at the mailing label on this newsletter.... EPFG needs your help to clean up and purge our data base of members and the newsletter mailings. If your label is green, we especially need you to respond, as our records indicate that your membership has expired (as of January 2000). If you have never become a member, or you do not wish to join, at least please subscribe to continue receiving the newsletter. In either case, speedy payment of \$40.00 for annual dues or \$12.00 newsletter subscription fee would be appreciated. Also, is the address correct? Is it reaching the proper folks? Please let us know by mail with your check, or by phone or email.

Again this month, you will find information concerning our educational festival on March 19th, and I encourage you to take advantage of this once-a-year opportunity to learn something which will help you become a better picture framer. As you should know by now, education is our (EPFG's) reason for being, and we try very hard to present programs which will be informative and interesting as well as

*(Continued on page 5)*

## QUESTIONS ABOUT PPFA

BY NANCY CHAPMAN

**1. Who is on the PPFA board and how do they get appointed.** There are 11 members (there used to be 25 but it was too unwieldy and not as effective as it should have been, according to a past board member who was at the meeting). The make up is 4 framers, 4 suppliers/manufacturers and the other 3 positions can vary between the two. A committee of 5, made up of past board members and others who have a wide base of "who they know" appoints them. As of Jan 1 there will be 3 board members who reside west of the Mississippi River. Our closest representation will be \_\_\_\_\_ from the Rocky Mountain Chapter. Each Board Member is assigned a certain area of the country and is supposed to stay in communication with the chapters there.

**2. About the CPF Exam.** The exam was begun in 1986. Anyone who took it before 1993 is "vested", anyone who takes it after then must re-certify every (2?) years. We were told this difference in requirements was a "political decision". I got the impression it was based mostly on the opinion of those who were already CPF's. They felt that the test was getting easier than when they took it. The current pass rate of the exam is 60%. To purchase all of the study materials and take the exam costs about \$425 dollars. You must be a member to take the test or to re-certify. In addition there are costs incurred in getting to someplace where the test is given, normally at one of the conventions.

It is true that 2 national chains train their framing staffs and give them a certificate upon completion. The certificate is a CF (not CPF) and their logo looks very much like the CPF logo. It is not very ethical, but is not illegal!



March 2000

*Newsletter Cost: free to EPFG members, \$1.00 for non-members*

*Serving Alaska & Washington*

## HERE'S WHAT HAPPENED

BY TERRY SCIDMORE

The February meeting of the EPFG, held at Lake City Picture Framing, was an open board meeting to give members a chance to meet the current board, and to participate directly in the decision making for meeting topics, places to meet, suggestions, concerns, and comments. Some great ideas were generated for future meetings, including the future of framing, health and business insurance, preparing for tax time, a look at labor and industry classifications, and ideas for effectively running your business rather than having your business run

*(Continued on page 3)*

**MARCH 19TH**  
7th Annual EPFG  
Education Festival at the  
Tukwila Embassy Suites  
Hotel.



## HOW TO CONTACT US

### Membership Dues, Advertising Payments:

Kioski Toda, EPFG Treasurer  
3058 Issaquah-Pine Lake Road  
Issaquah, WA 98027  
Phone: (425) 557.5494

### Change of Address:

Nancy Chapman  
15209 263 Ave. SE  
Issaquah, WA 98027  
Phone: (425) 392.7334  
biminidesigns@hotmail.com

For changes of address please include old and new address information.

### Classified Ad Copy, Display Ad Artwork:

Tim Taricco  
P.O. Box 411  
Redmond, WA 98073  
Fax: (630) 839-4591  
frameguy@myframeshop.com

### Classified ads

Free for EPFG members, \$10 for non-members

### Display Ad Artwork

Digital artwork is requested. PC format preferred / Mac format okay. Submit via e-mail or on disk.

### Publishing Deadline

20th of the month prior to distribution.

## 1999-2000 EPFG Officers

### President

Paul Knoop, CPF  
*the framemakers*  
253.564.2320  
pknoop@earthlink.net

### Vice President

Donna Rickman, CPF  
*Finishing Touches*  
425.338.0932  
rrickman@aol.com

### Treasurer

Kiyoshi Toda, CPF  
*Accent On Framing*  
425.557.5494

### Secretary

Terry Scidmore, CPF  
*The Mitered Corner*  
206.433.1145

### Board Of Directors

Joe Garitone, CPF  
*Larson-Juhl*  
800.223.0307 x455

### Joe Huber

*Studio Moulding*  
800.262.4174 x217

### Ben Edwards

*Framers' Inventory*  
206.793.0613

### Ray Miles

*National Glass*  
800.521.7061

### Past President

Frank Larson, CPF  
*Larson Fine Art Services*  
425.482.0549

The EPFG Newsletter is published monthly by Tim Taricco.  
**Mailing Address:** P. O. Box 411 - Redmond, Washington 98073-0411. **Phone:** (206)235-8467 **Fax:** (630)839-4591  
**E-mail:** frameguy@myframeshop.com **Web Site:** http://www.myframeshop.com. Newsletter Design ©MM T. M. Taricco and Newsletter Content ©MM Evergreen Picture Framers Guild. All rights reserved. Do not duplicate or redistribute in any form.

Need Training for New Employees?

**SEE WHAT YOUR DOLLAR  
CAN DO IN CANADA**

**The Canadian Picture  
Framer's School**

#1, 20678 Duncan Way  
Langley, B.C.

providing excellent thorough  
instruction in picture framing for  
over 10 years. Phone or fax  
for more info:

Ph: 604-533-5328  
Fax: 604-533-9680

**VICTOR  
MOULDING CO.**

Have you received your **VICTOR  
VALUE** and **Avalon** samples yet?  
Call your sales rep today for these  
two exciting moulding lines that are  
sure to enhance your selection.

**Chuck Bigford**  
**1-800-359-2829 ext.3715**

3439 S.W. Bond  
Portland, OR 97201

**1-800-366-2810**



SEATTLE, WA 98133

**THE ART DOCTOR**Restoration of Oil Paintings, Japanese Screens,  
Art on Paper, Art Objects**NANCY G. WHITE**  
Restorer(206) 783-9160  
By Appointment**Pacific Framing Supply***"Serving all of your framing needs"***Brad Airhart & John Cave**Salem, OR 97304  
Phone: 1-800-872-4445  
FAX: 1-503-363-7273Woodinville, WA 98072  
Phone: 1-800-292-3202  
FAX: 1-206-486-4978WILLIAMSON • FOAMCORE • TRUVUE GLASS/MILLER MATBOARD  
CLARK • DESIGNER WOOD & METAL • COLONIAL • BURNICHLimited to  
stock on hand**WILLIAMSON**Please call for  
more info**Discontinued Item Sale****20% OFF LENGTH • 25% OFF CHOPS**16-0420-7277, 16-0420-7377, 38-6464-6304, 38-6464-6306,  
38-6464-6309, 40-2210-7277

METAL FRAMES ART

6010 EAST ALKI WAREHOUSE #5  
PHONE 800 344-7329 509 535-3440SPOKANE WASHINGTON 99212  
FAX 800 344-5003 509 535-3466ANAHEIM | DENVER | PORTLAND  
SEATTLE | COLORPLAK.COMProviding art laminating services for frame  
shops all over the West coast!

800-305-1953

## HERE'S WHAT HAPPENED

*(Continued from page 1)*

you. Roundtable discussions were another popular idea with suggestions for framing tips, shortcuts, techniques, goodies, gadgets, and gizmos, sharing credit card, health care, and business insurance plan information, and comparing the various framing software programs on the market. Future board meetings will be held on Tuesday March 28, May 30, July 25, September 26, and November 28. The board meets at the Peking Wok, 12816 SE 38th Place from 7 to 9 PM. Board meetings are open to any member. We encourage you to come and participate.

Our annual Education Festival is Sunday, March 19 at the Embassy Suites hotel in Tukwila. There is a full schedule of mini and long seminars on a variety of subjects, and the cost can't be beat! The festival hours will be from 8:30 AM to 4:30 PM with a social hour following. This year the awards ceremony and installation of new officers will be held during the lunch banquet. This is a great opportunity to have fun, learn something, and socialize. You can register by mail with treasurer Kiyoshi Toda, Accent On Framing, EPFG Registration, 3058 Issaquah-Pine Lake Road SE, Issaquah,

WA 98029. If you need a registration form, contact Ben Edwards (1-800-543-2467, ext 400) or Tim Taricco (frameguy@myframeshop.com).

This year our election of the new board will be done by mail and at the Education Festival March 19. If you are a current member, you will be receiving your ballot by mail soon. You may return your ballot by mail, or bring it with you to the Festival. Ballots coming back by mail should be postmarked by March 11. There will be a ballot box and ballots available for new members who join on the 19th or if your membership is received too late to mail a ballot to you. Ballots can be deposited before 9 AM on the 19th. If you have questions, please call Terry Scidmore at 206-433-1145.

Our print competition information was overlooked in the last newsletter but it's not too late to participate. This year's print is "Nothing Like Jonathons" by Robert Duncan in a 5 x 7 size. We thought that it reflected a northwest theme and was small enough to be economical to frame creatively (as well as to mail if you are unable to enter in person). Competitions are

*(Continued on page 9)*



## Florentina™

*A collection of beautiful oxidized colors inspired from the natural earth elements of Florence. The latest addition to the Larson-Juhl Classic Collection.*

*For more information on Florentina and other Larson-Juhl framing products call:  
(800) 438-5031*

*or contact your Larson-Juhl sales representative  
Voice Mail: 800-223-0307*

*Stephen Dean - ext. 454 • Joe Garitone - ext. 455 • Paul Anderson - ext. 456*

## LARSON · JUHL

CUSTOM FRAME THE BEAUTY OF YOUR HOME

# NATIONAL GLASS

17030 WOODINVILLE-REDMOND ROAD, WOODINVILLE, WA. 98072

**QUALITY PRODUCTS AND EXCELLENT SERVICE!** NATIONAL GLASS INVENTORIES THE LARGEST SELECTION OF PICTURE FRAMING GLASS IN THE PACIFIC NORTHWEST.



NATIONAL GLASS

**TRU VUE AND SANDEL PREMIUM, REFLECTION CONTROL, SATINVIEW, CONSERVATION SERIES GLASS, IMAGE PERFECT, DENGAS, AND CRYSTALVIEW.**

**Now Available - AR Glass & Museum Glass!**

**ALSO AVAILABLE: FOAM-X, MIRROR AND ACRYLICS**

**EVERYTHING YOU NEED AND FREE DELIVERY ARE ONLY A PHONE CALL AWAY!**

(425) 488-8126

1 (800) 521-7061

fax (425) 488-3712



**Jeff Schuffman**  
Sales Representative

1433 W. Frankford Rd. #100 Carrollton, Texas 75007  
972-466-0721 • 972-466-3662 Fax  
800-527-0421 • 800-817-0524 Fax  
Ext. 882



2928 4th Ave S • Seattle, WA 98134  
Wholesale Picture Frame Supplies  
206-292-9664  
800-423-6287

Software Suite for all Versions of Windows  
Galleries & Frame Shops Networking User Friendly!

**FERENSOFT**  
**TRiO!**

- Art
- Customers
- Framing

Point of Sale and Business Management Software. *Y2K Ready!* See why people are switching to **FS TriO!** Seattle 206-282-1775  
[www.ferensoft.com](http://www.ferensoft.com)



**Edgar Solares**  
Account Representative  
Telephone • 206-440-1545

9415 Telfair Avenue • Sun Valley CA 91352  
Telephone • 818-767-8700 • 800-668-3627

**TRUE GLASS**  
FOR EVERY NEED

<p><b>PREMIUM SERIES GLASS</b></p> <ul style="list-style-type: none"> <li>• PREMIUM CLEAR*</li> <li>• REFLECTION CONTROL*</li> <li>• AR** REFLECTIVE FREE</li> </ul>	<p><b>CONSERVATION SERIES GLASS</b></p> <ul style="list-style-type: none"> <li>• CONSERVATION CLEAR*</li> <li>• CONSERVATION REFLECTION CONTROL*</li> <li>• MUSEUM GLASS*</li> </ul>
--	--

## OUR PRESIDENT'S PEN

*(Continued from page 1)*

helpful to everyone in our area. Please register now, so that we can adequately prepare for a fun day. Note also that one of the sessions has been replaced with something of a "show and tell" to help make use of leftovers around the shop, so if you have an idea along this line, bring a sample to share with others, and stop in to see just what you can do with those scraps we all generate. See the article in the newsletter for further information.

Also, if you are a member and have not mailed in your ballot for the election of Officers and Board members, please bring it with you to the Embassy; a Ballot Box will be there for your convenience.

The Feb meeting at Lake City Picture Framing was well attended, probably because many of us know how good the refreshments would be! Lynn and crew have done a great job in that department, and thanks again for all the goodies. There were some great ideas generated for programs and locations to get us through the rest of the year, and a committee

*(Continued on page 8)*

*Fabric & Liners*

*The Softer Side of Framing*

Hundreds of colors and textures --- Exclusive pH Neutral Fabrics



**Fabrics for Framers**

Dial Toll-Free (888) F.FABRIX (332-2749)



### FRAMERS' INVENTORY

WOOD MOULDING  
Bay, Framers' Inventory,  
LaMarche, Max, Roma

METAL MOULDING  
Nielsen

MATBOARD  
Bainbridge, Crescent, Rising, TruVue

GLASS & FOAMBOARD  
Sandel, TruVue  
Bainbridge, Bienfang, & Hart

EQUIPMENT  
C&H, Eclipse, Fletcher  
Mitre Mite VN42, Seal/Hunt Mounting

SERVICE  
Daily delivery in Portland & Seattle Metro areas,  
Overnight chop service

5000 SE 18TH AVENUE, PORTLAND, OREGON 97202  
LOCAL (503)236-9293 . TOLL FREE(800)543-2467  
FAX(503)238-3899



8214-B South 192nd St., Kent, WA 98032

### FREE FREIGHT

On all orders over \$100.00 in OR and WA

JOE HUBER

Orders: (800) 262-4174  
Voice Mail Ext: 217  
Fax: (888) 423-1814



### CORONA

1150 Industry Drive Tukwila, WA 98188  
Division of RCI, Inc.



The choice of professionals, CORONA Cold & Hot/Cold Vacuum presses. Complete mounting/laminating supplies. Originators of BERTO and Corona Hot/Cold Unimount adhesives...the industry mainstays for over 20 years. 'The Mounting Specialists'.

Suppliers to the Picture Framing Industry for over  
30 years

206.575.2727 Fax: 206.575.2667



Hartung Glass was the first company in the Northwest Region to deliver to the Picture Framing Industry. We have been serving the Picture Framers in our area for over twenty years and offer the largest inventory of stock sheets in the Pacific Northwest. We feature all of the top manufacturers, including Sandel, Tru-View, and Cyro, with scheduled deliveries to most areas of Washington. We carry many types of framing glass, including:

- |                 |                    |
|-----------------|--------------------|
| Clear           | Sandel Superior    |
| Anti-Reflection | Sandel Crystalview |
| Non-Glare       | Tru-View & Sandel  |
| Conservation    | Tru-View           |
| Preservation    | Sandel             |
| Museum Glass    | Tru-View           |

Call today to schedule a delivery!

**Hartung now stocks  
3/16 mirror with 1"  
bevel for framing.  
Call our helpful customer  
Service Department today to  
place your order!**

425/656-2626  
800/552-2227



6001 Santa Monica Boulevard, Los Angeles, California 90038  
 Tel # (213) 469-9006 • Fax # (213) 469-0940  
 World Wide Web: <http://www.FramingFabrics.com> • E-mail: [info@fmi.com](mailto:info@fmi.com)

# New Pre-Covered Lip Liner

Ask about our  
Distributors Discount.

Expanded Liner Selection

## **Framing Fabrics & Moulding International**

is very happy to introduce NEW LINERS. With the recent expansion of our liner offerings, we are able to provide our customers with a complete liner selection, at very competitive prices. These seven new additions include a flat profile in two sizes, a bevel profile in two sizes and a scoop profile in three sizes, all with hand-finished lips of bright gold, antique gold and antique silver. These lip liners are available in four fabrics, 100% BELGIQUE Natural Linen; Union Blend of MANHASSET Natural and Oyster and Antique Satin MARQUIS Black.

### LIP FINISHES

Bright Gold ❖ Antique Gold ❖ Antique Silver

### FABRICS

Manhasset Natural ❖ Manhasset Oyster  
 Belgique Natural ❖ Marquis Black

All are pre-covered. However, we are also able to meet most of your custom needs (*Custom Wraps*), just call and ask our Customer Service Department personnel. Upon request, we can cover our lip liners with any of the 500 fabrics we sell. A 50 ft. minimum applies to liners cut to 6 & 4 or 5 & 5 ft. lengths; a 100 ft. is required on liners in standard 10 ft. lengths.

These liners are in addition to the original thirty liner profiles we offer in Primed, Pre-covered and *Custom Wrapped* both in length and chop.

#### FLAT

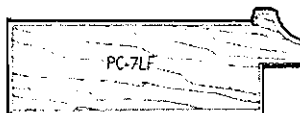
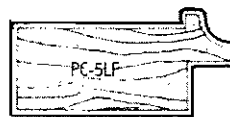

#### BEVEL

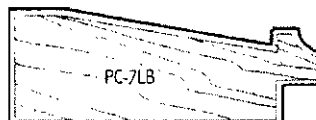

#### SCOOP

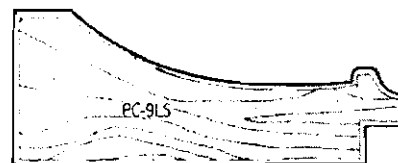
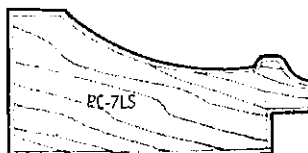
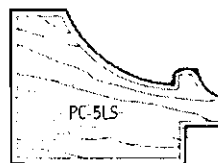

Shown Actual Size



# Chances are you started out with a LOGAN Mat Cutter Have you seen what we've done lately?

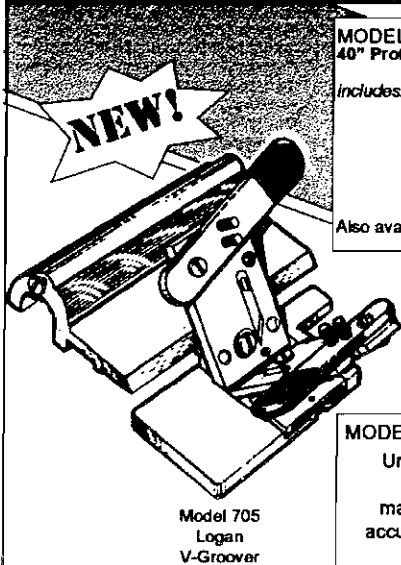

Model 705  
Logan  
V-Groover

## MODEL #650 *Framer's Edge* MAT CUTTER 40" Professional Production Matcutter

- Includes:
- Ergonomically designed Dual straight and Bevel cutting head
  - Production Stops
  - Parallel Mat Guide
  - Start and Stop Indicator for line to line cutting.
  - 27" Squaring Arm

**Suggested List Price \$599.95**

Also available in a 60" version MODEL #660 *Framer's Edge* \$799.95

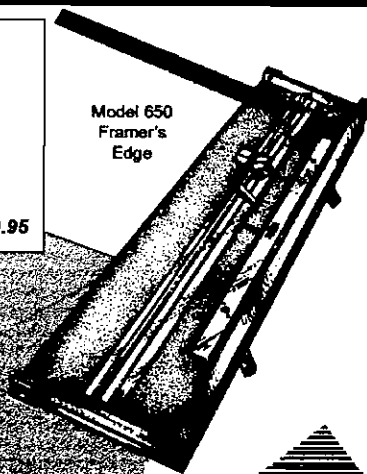

Model 650  
Framer's  
Edge

## MODEL 705 LOGAN V-Groover patented

Unique "push-pull" surface V-Groover that cuts beautiful V-Grooves on the surface of the matboard. Works entirely with stops provided for accurate V-Grooving in seconds with zero overcuts. Endless creative possibilities!!

**Suggested List Price \$125.00**

## MODEL 706 Universal V-Groover patented

Works on professional mat cutters using a 5/8" thick cutting bar rod including Fletcher® and C&H® professional matcutters.

**Suggested List Price \$150.00**



GRAPHIC PRODUCTS, INC.  
1100 MICHIGAN STREET • WAUCONDA, ILLINOIS 60084  
NATIONWIDE TOLL FREE 1-800/331-4222  
TOLL FREE FAX 800/331-4329

See us at <http://www.artproducts.com>

E-MAIL: [Logan-Graphic-Products@worldnet.att.net](mailto:Logan-Graphic-Products@worldnet.att.net)

## OUR PRESIDENT'S PEN

(Continued from page 5)

volunteered to help Tim Taricco get the content portion of our web site prepared. Look for more details on this important undertaking in conjunction with the folks to the South, Cascade Picture Framers Guild. Thanks to those who agreed to help with this project.

What about the Lending Library? Have you taken advantage of this service to update your skills, or learn a new one? Books and videos on both the technical side of framing and on the business side of frame shop operations are yours for the asking. Business forms, contracts, shop layout ideas, financial how-to's are just a few of the things there to help improve efficiency and the bottom line. Just contact the librarian, Bob Holcomb at Millennium Gallery, 425-895-8822, for details.

### It's About Choices...



Crescent Regular Matboard, with the greatest array of colors, is the **right choice** for everyday decorative

framing. Crescent Whitecore Basics, with its non-yellowing white core, is the **ideal choice** for the

design requirements of today's contemporary decor. Crescent Rag Max remains the **only choice** for conservation framing.

With its naturally 100% acid- and lignin-free cotton core, it's the premier choice for protecting priceless works

of art and irreplaceable memories.



**Crescent**

WE GIVE YOU THE RIGHT CHOICES!  
<http://www.crescent-cardboard.com>

Crescent Cardboard Company, 100 West Willow Road, Wheeling, Illinois 60090, Tel. 1-847-537-3400, Fax 1-847-537-7153





## HERE'S WHAT HAPPENED

*(Continued from page 3)*

a great way to show off your talent and creativity, and we all appreciate the high degree of skill and professionalism our members exhibit in their entries. The print is available by mail for \$4. Mail your check to Nancy Chapman, 15209—263rd Ave SE, Issaquah, WA 98027. Nancy may be reached by phone at 425-392-7334, or e-mail at [biminidesigns@hotmail.com](mailto:biminidesigns@hotmail.com).

The last topic covered for the evening was the EPFG Web site. Tim Taricco explained about the plans for the site and several members volunteered to work with Tim in developing it. They will present their ideas to the board at the march 28 board meeting. Many members are enthusiastic about the possibilities a guild Web site can offer to them, and you are encouraged by the board to contribute to our new venture.

### NURRE CAXTON

FRAMES OF DISTINCTION



*"We're Obsessed  
With Customer  
Satisfaction"*

#### **Pamela Neal**

Sales Representative for  
Washington, Wyoming, Montana  
Oregon and Idaho

1-800-255-1942, press 6, ext. 4011

for voice mail

1-800-377-3300 fax

1-800-910-8966 pager

We promise friendly reliable service  
same day chop service free UPS  
for orders of 3 chops or more  
(wood and Nielsen metal combined)

## MEMBERSHIP APPLICATION & UPDATE FORM

**Company Name:**

**Phone:**

**Contact Name:**

**Fax:**

**Street Address:**

**E-Mail:**

**City:**

**Web Site: <http://>**

**State:**

**Zip:**

Complete this form and return it with your membership dues of \$40.

**Mail to:** Kiyoshi Toda, CPF— Accent On Framing, 3058 Issaquah-Pine Lake Rd Se, Issaquah, WA 98027

For more information about the Evergreen Picture Framers Guild, please contact: Nancy Chapman, 15209 263 Ave. SE, Issaquah, WA 98027. Phone: (425) 392.7334. E-mail: [biminidesigns@hotmail.com](mailto:biminidesigns@hotmail.com)

## CLASSIFIED ADS

**For Sale:** 500TX Dry Mount Press. Turnstile for metal frames. Two matboard cabinets. 360-876-4377

**March 2000**

**EPFG  
Education  
Festival  
March 19th — 9 AM**

**April 2000**

11th – General Meeting – 7 PM

**May 2000**

9th – General Meeting – 7 PM  
*The Frame Makers*—Tacoma,  
“Packaging & Crating”

**June 2000**

13th – General Meeting – 7 PM  
*Museum Quality Framing*—  
Seattle, “The Future of Framing”

**July 2000**

11th – General Meeting – 7 PM  
“Goodies & Gadgets”

**August 2000**

Everett AquaSox Baseball game  
& picnic

**September 2000**

12th – General Meeting – 7 PM  
*William Bounds Custom  
Framing*—Burlington

**October 2000**

10th – General Meeting – 7 PM

**November 2000**

14th – General Meeting – 7 PM  
*Colorplak*—Redmond

**December 2000**

No Meeting



T. M. Taricco  
P. O. Box 411  
Redmond, Washington 98073-0411

SEE PAGE TWO OF THIS  
NEWSLETTER FOR ADDRESS  
CHANGE CONTACT INFORMATION

**ATTENTION: FRAME SHOP**





Updated Edition

PRINT COMPETITION  
INFORMATION ON THE BACK!



EVERGREEN

SUNDAY  
MARCH 19, 2000

CLASS SCHEDULE  
& REGISTRATION  
FORM INSIDE

# 7TH ANNUAL EPFG EDUCATION FESTIVAL

Enclosed you will find the class schedule for the 7th Annual EPFG Education Festival. You will notice that the event this year has a wide variety of seminars. You can mix and match Mini Sessions with Full Sessions to make up your own schedule for the day.

This year's event will be at the Embassy Suites Hotel in Tukwila again. The schedule for the day has been changed to include a Luncheon Awards Banquet, rather than an evening event. This should make the day a little shorter and a lot more enjoyable for all.

## SCHEDULE OF EVENTS

8:30 AM – 9:00 AM  
Registration

9:00 AM – 12:00 PM  
First Session Classes

12:00 PM – 1:30 PM  
Lunch  
Awards Banquet

1:30 PM – 4:30 PM  
Second Session Classes

4:30 PM – 5:30 PM  
EPFG will be hosting a  
Social Hour with  
1 complimentary drink  
for each person in  
attendance

Embassy Suites Hotel  
15920 West Valley Hwy  
Tukwila, WA 98188  
(425) 227-8844

## A SPECIAL GUEST INSTRUCTOR

As you look through the list of classes this year, you will notice that many of the instructors are names of people you know, people who work in our industry in the Pacific Northwest. For our two full session seminars, we have invited, nationally known instructor, Nona Powers CPF.

Nona Powers, CPF, graduated with a Masters of Art from San Diego State University in 1978, and has been active since in the picture framing industry as a framer, gallery owner, educator, consultant, and author. Winner of numerous awards for her picture framing, she is also a competition judge for PFFA. Nona has been active as a lecturer and instructor since 1979, and has authored numerous articles for trade publications as well as several newspapers in California, her home state. As an education consultant for Nielsen-Bainbridge and Colorado Moulding, she now spends many days a year "on the road", helping to improve the quality of picture framing throughout the United States and Canada. For additional information concerning her career, please visit her web site on the internet, [NonaPowers.com](http://NonaPowers.com).



News  
Flash

FACTS fails for festival! Frantic framers flounder furtively for formidable, fulfilling, and fun feature! Forthwith fruitful fortune fortuitously flings fetching find! Framers fashion "Treasures From Trash—A Look at the Buy Products in Your Dumpster." Come see and share ways to utilize those scraps of matboard and moulding that are just too good to throw away. Bring your special treasures to add to our array of ornaments, cards, magnets, shelves, boxes, jewelry and other wonders that the resourceful framer can create from leftovers.

## AWARDS BANQUET LUNCH CHOICES

### Reservations are Requested

*includes fresh market greens, chef's selection of rice, potato, or pasta, steamed seasonal vegetables, rolls and butter, desert and coffee or tea.*

#### Chicken Saltimbocca

*Breast of chicken, oven baked with fresh sage, prosciutto and provolone cheese served on our homestyle marinara sauce.*

#### Vegetarian Entree

*Chef's Choice*

#### Halibut Parmesan

*Tender filet of halibut lightly coated with egg and parmesan bread crumbs baked to golden brown.*

**Vote Inside**



**TIME  
SCHEDULE**

**EPFG EDUCATION FESTIVAL  
CLASS SCHEDULE**

8:30 – 9 AM CLASS REGISTRATION		
9 AM – 12 PM Full Seminar	<b>SOLVING COMMON FRAMING PROBLEMS</b> Nona Powers CPF	You have a 40-inch mat cutter and the mat you inadvertently sold measures 42 inches. How do you solve this problem? During this interactive seminar, you'll find the answer, as well as many other solutions to common framing problems related to design, fabrication, preservation, sales resistance, pricing, shadow boxing, computers and much more.
9 – 10:15 AM Mini Seminar	<b>WEB SITE DESIGN (1ST SESSION)</b> Linda Horsfall	Should you put your business on the web? What does that mean, and how is it done? How much does it cost? These are some of the web-based questions we will discuss in this class. We will cover site design tools, how a site is published, where to find resources on the web to help you create a site and look at good and ad site design. We will also define many of those pesky acronyms like www. isp. html. jpeg. gif. url. etc.
9 – 10:15 AM Mini Seminar	<b>SECRETS TO SELLING UP</b> Joe Huber, Ben Edwards, Joe Gariton CPF	Sales counter techniques for promoting higher end sales. How to overcome sticker shock, increase profit margins and raise quality levels in your shop.
10:30 – 12 PM Mini Seminar	<b>HOW TO IDENTIFY &amp; SELL FINE ART</b> Jeff Schuffman, Susy Stevens	This informative and entertaining seminar will give you a working knowledge of some of the most popular fine art printing techniques used today. Learn to identify these types of prints and most importantly, how to use this knowledge to buy and sell fine with more confidence.
10:30 – 12 PM Mini Seminar	<b>TREASURES FROM TRASH</b>	Come see and share ways to utilize those scraps of matboard and moulding that are just too good to throw away. Bring your special treasures to add to our array of ornaments, cards, magnets, shelves, boxes, jewelry and other wonders that the resourceful framer can create from leftovers.

For questions about the festival, please contact Terry Scidmore, 206-433-1145.

**MORE CLASSES**





# REGISTRATION / RESERVATIONS

Please Return this by March 13th

## EDUCATION AND BANQUET FEES

<b>Individual</b>	EPFG Member	\$50.00 – Includes registrants choice of classes, luncheon banquet.
	Non-Member	\$90.00 – Includes the above plus 2000 EPFG membership.
<b>Frame Shop Group</b>	EPFG Member	\$125.00 – Includes 4 registrants choice of classes, 4 luncheon banquet.
	Non-Member	\$165.00 – Includes the above plus 2000 EPFG membership.
<b>Additional Luncheon</b>	EPFG Member	\$15.00 – per individual
	Non-Member	\$30.00 – per individual

## FRAME SHOP INFORMATION

Company Name \_\_\_\_\_ Contact Name \_\_\_\_\_

Address \_\_\_\_\_ Phone (    ) \_\_\_\_\_

City/State/Zip \_\_\_\_\_

## REGISTRATION / RESERVATIONS

Name _____	<input type="checkbox"/> Chicken	TOTAL / EA
Class Choices	<input type="checkbox"/> Fish	
	<input type="checkbox"/> Vege	
Name _____	<input type="checkbox"/> Chicken	
Class Choices	<input type="checkbox"/> Fish	
	<input type="checkbox"/> Vege	
Name _____	<input type="checkbox"/> Chicken	
Class Choices	<input type="checkbox"/> Fish	
	<input type="checkbox"/> Vege	
Name _____	<input type="checkbox"/> Chicken	
Class Choices	<input type="checkbox"/> Fish	
	<input type="checkbox"/> Vege	

Please make your check payable to **EPFG** and return this form by March 13th to:

**Accent On Framing  
EPFG Registration  
3058 Issaquah-Pine Lake Rd  
Issaquah, WA 98027**

**Total \$**

(Over Please)

**Return This Form**



# EPFG AWARDS OF EXCELLENCE

One of the most important parts of the EPFG Education Festival is the awards given to recognize excellence in our industry. Again this year, awards will be given for the **Vendor of the Year**, **Sales Representative of the Year**, **Customer Service Person of the Year** and **Delivery Driver of the Year**. Please take time to carefully choose your nominations for each award. *Please return by March 13th.*

### Delivery Driver of the Year

The Delivery Driver of the Year should be the driver who: professionally represents his/her company well, gives 110%, and represents what is good about our industry.

Driver Name \_\_\_\_\_ Company Name \_\_\_\_\_

### Customer Service Person of the Year

The Customer Service Person of the Year should be the person who: professionally represents his/her company well, gives 110%, and represents what is good about our industry. Consider nominating a customer service representative, receptionist, warehouse employee, or Will-Call representative for this award.

CSP Name \_\_\_\_\_ Company Name \_\_\_\_\_

### Sales Representative of the Year

The Sales Representative of the Year should be the person who: professionally represents his/her company well, gives 110%, and represents what is good about our industry.

Rep. Name \_\_\_\_\_ Company Name \_\_\_\_\_

### Vendor of the Year

The Vendor of the Year should be the company that provides: 1) excellent client service, 2) Product Quality & Selection, 3) Prompt Delivery & Shipping, and 4) represents what is good about our industry.

- |  |   |   |   |
|--|---|---|---|
| <input type="checkbox"/> <i>Art Laminators/Colorplak</i> | <input type="checkbox"/> <i>Framing Fabrics</i>   | <input type="checkbox"/> <i>National Glass</i>                      | <input type="checkbox"/> <i>Tru-View</i>        |
| <input type="checkbox"/> <i>Arquati</i>                  | <input type="checkbox"/> <i>Hartung Glass</i>     | <input type="checkbox"/> <i>Nurre Caxton</i>                        | <input type="checkbox"/> <i>Victor Moulding</i> |
| <input type="checkbox"/> <i>Corona / Omega</i>           | <input type="checkbox"/> <i>Jayeness</i>          | <input type="checkbox"/> <i>Pacific Framing Supply</i>              |   |
| <input type="checkbox"/> <i>Crescent Cardboard</i>       | <input type="checkbox"/> <i>Larson Juhl</i>       | <input type="checkbox"/> <i>Studio Moulding</i>                     |   |
| <input type="checkbox"/> <i>FerenSoft</i>                | <input type="checkbox"/> <i>Logan Mat Cutters</i> | <input type="checkbox"/> <i>The Art Doctor</i>                      |   |
| <input type="checkbox"/> <i>Framers' Inventory</i>       | <input type="checkbox"/> <i>Mat Maestro</i>       | <input type="checkbox"/> <i>The Canadian Picture Framers School</i> |   |
|  | <input type="checkbox"/> <i>Metal Frames Arts</i> |   |   |

Choose one of the EPFG supporting vendors above or write in your nomination.

**FIRST CHOICE** \_\_\_\_\_  
**SECOND CHOICE** \_\_\_\_\_

Return This Form



# EPFG EDUCATION FESTIVAL

## CLASS SCHEDULE

### TIME SCHEDULE

<b>LUNCH AWARDS BANQUET</b>		<b>12 – 1:30 PM</b>
<p>Recognizing good design is instinctive, but manipulating design elements can be learned. To understand the interaction of color - the most powerful presentation element - you must find out what it is and how it works. Use this knowledge to choose color and design concepts for matting and framing. Concepts in this workshop are covered with the use of slides and visual aids.</p>	<p><b>APPROACH TO DESIGN</b></p> <p>Nona Powers CPF</p>	<p><b>1:30 – 4:30</b></p> <p>Full Seminar</p>
<p>Enter the exciting, harrowing and profitable world of canvas transfers. Hands on techniques needed to produce consistently beautiful prints. All materials and artwork provided.</p>	<p><b>CANVAS TRANSFER FOR DUMMIES</b></p> <p>Don Jones CPF</p>	<p><b>1:30 – 2:45</b></p> <p>Mini Seminar</p>
<p>Should you put your business on the web? What does that mean, and how is it done? How much does it cost? These are some of the web-based questions we will discuss in this class. We will cover site design tools, how a site is published, where to find resources on the web to help you create a site and look at good and ad site design. We will also define many of those pesky acronyms like www. isp. html. jpeg. gif. url. etc.</p>	<p><b>WEB SITE DESIGN (2ND SESSION)</b></p> <p>Linda Horsfall CPF</p>	<p><b>1:30 – 2:45</b></p> <p>Mini Seminar</p>
<p>A discussion and display of methods for mounting paper and dimensional objects where paper hinges and paste are not appropriate, or cannot be used. Methods shown will use readily available items, some of which can be easily made in the shop, and others purchased from trade suppliers.</p>	<p><b>CONSERVATION MOUNTING</b></p> <p>Paul Knoop CPF</p>	<p><b>3:00 – 4:30</b></p> <p>Mini Seminar</p>
<p>Learn how to sell mirrors and tricks to hanging large objects.</p>	<p><b>REFLECTIONS ON PROFIT</b></p> <p>Ray Miles, Frank Larson CPF</p>	<p><b>3:00 – 4:30</b></p> <p>Mini Seminar</p>

For questions about the festival, please contact Terry Scidmore, 206-433-1145.

# FRAMING COMPETITION

Once again the EPFG will sponsor a framing competition at the annual Spring Festival. This is an opportunity for each of you to show off your best creativity and technical skills. As evidenced by the entries the past two years, talent abounds in our area. We will repeat the same format as last year—a print has been chosen and each framer can present it in his/her own way.

When it was time to get the prints ordered the theme for the Festival had not yet been chosen. So, we decided to use a “Northwest” theme. I suggested “Slugs”, but was voted down (I imagine that is OK with all of you!). So, “Apples” was chosen instead. There are many prints with apples that are in our small size range so it was difficult to decide. With the help of several other members of the Guild “Nothing Like Jonathans” by Robert Duncan won the vote. This print

depicts two children picking apples in an orchard with their dog. The size is just 5x7 and there are a variety of colors used – we hope this encourages you to use a lot of creativity without having to use a lot of materials.

The cost will be \$2 if purchased at a Guild meeting and \$4 for one to be mailed to you. I will send one to you if you send me a check for \$4 and your address. The packet includes the print, an Entry Form, a Judging Form and a Description Form. The Judging form is new, an abbreviated version of the one used in the past. Because of limited time for the judging we needed to shorten the form.

Nancy Chapman  
 15209—263 Ave SE  
 Issaquah, WA 98027  
 425-392-7334

The Embassy Suites Hotel is located just off Interstate 405 in Tukwila. Take the West Valley Hwy exit off I-405. The hotel is just minutes away from the Seattle-Tacoma airport.

**Embassy Suites Hotel**  
 15920 West Valley Hwy  
 Tukwila, WA 98188  
 (425) 227-8844

