

OUR PRESIDENT'S PEN

BY PAUL KNOOP, EPFG PRESIDENT



Now, a quick welcome to a new Officer and 2 new Board members. Lynn Clark, of Lake City Picture Framing, has volunteered to serve out the remainder of Kiyoshi Toda's term as Treasurer, and the new Board Members elected were Helen Kane, CPF, Anabels Framing and Gallery, Everett WA, and Barbara Mercer, MFA, of Edmonds Frame Design, Edmonds WA. Those of us who have been around the Guild for some time know these ladies well, as they have been active members from the get-go. It will be a pleasure to have them to work with. Returning Officers include the VP, Donna Rickman, CPF, Terry Scidmore, CPF, Secretary, and myself as President. Ray Miles will continue on the Board; Ben Edwards, Joe Garitone, CPF and Joe Huber will share a "spot" which can be described by "other duties as assigned", a phrase many of you may recognize. Basically, they formed an ad hoc committee to help us whenever and wherever needed. My thanks to the outgoing Officers and Board members who have served the Guild so well over the last years.

Your Board has voted to raise the issue of re-affiliation with National PPFA as a Chapter, and bring it before the membership for a vote in June. Next month, EPFG members will receive a ballot to that effect, and we need to hear from you. Three years ago when we "seceded", the vote was very close, and every member deserves a say in the direction of the Guild. If you have not familiarized yourself with both sides of the issue, now is the time to do that. Questions may be answered by any of the Board members, the National PPFA Staff, and EPFG members who were directly involved with the prior vote, such as Paul Miller, CPF, one of our Past Presidents.

(Continued on page 5)

MAY IN REVIEW

BY PAUL KNOOP

The May meeting at the frame makers, Tacoma, was well attended, and the program, which discussed packing and shipping artwork, contained some very useful information and good advice for all framers. Mr. Bill Young, of The Packaging Store, discussed "Professional" packing and shipping services and several reasons for using such a service rather than doing it yourself. Probably most importantly, a good packager will know the proper way to do it, and will have the right materials readily available. Insurance is a big concern, as most shippers (UPS, FEDEX, etc) will not insure antiques and art works at a high enough value to provide adequate protection. The Packaging Store, for example, has its own insurance that will cover the total value of any shipment. If an item is lost or damaged, the customer has a choice of getting mad at you or a packaging agent, and which is preferable?? Also, a shipping company (with adequate insurance coverage) will replace damaged or lost items, and you will not have to eat the cost. Always inquire of your packager/shipper concerning the insurance coverage!!

However, if you choose to pack and ship for your customers, many companies provide the appropriate materials, and one of those provided samples, handouts, and catalogues for the attendees. The company is Masterpak, and they have a web site www.masterpak-usa.com that you can visit to get more information. Also, our lending library has copies of the handouts that you can review.



June 2000

Newsletter Cost: free to EPFG members, \$1.00 for non-members

Serving Alaska & Washington

HAS ES

THANKS FOR THE GOOD TIMES

BY TIM TARICCO

After nearly 13 years in the picture framing industry, I have moved on to a new challenge. At the beginning of May, I took a position at a small advertising agency. I am in charge of Web site development and Internet marketing strategies. I have been creating Web sites in my free time for about 4 years now and have learned enough to make it my career.

I have enjoyed my time framing and have been honored to edit this publication for the last 3 years. But since I will not be closely connected to

(Continued on page 2)

NEXT MEETING

JUNE 13TH @ MUSEUM
QUALITY FRAMING -
QUEEN ANNE



HOW TO CONTACT US

Membership Dues, Advertising Payments:

Lynn Clark, EPFG Treasurer
c/o Lake City Picture Framing
14028 Lake City Way NE
Seattle, WA 98125
206.363.2100

Change of Address:

Paul Knoop
c/o The Framemakers
6724 West 19th
University Place, WA 98466
253.564.2320
pknoop@earthlink.net

For changes of address please include old and new address information.

Classified Ad Copy, Display Ad Artwork:

Don Jones
c/o Finishing Touches
15704 Mill Creek Blvd
Mill Creek, WA 98012
425.338.0932

Classified ads

Free for EPFG members, \$10 for non-members

Display Ad Artwork

Digital artwork is requested. PC format preferred / Mac format okay. Submit via e-mail or on disk.

Publishing Deadline

20th of the month prior to distribution.

2000-2001 EPFG Officers

President

Paul Knoop, CPF
the framemakers
253.564.2320
pknoop@earthlink.net

Vice President

Donna Rickman, CPF
Finishing Touches
425.338.0932
rickman@aol.com

Treasurer

Lynn Clark
Lake City Picture Framing
206.363.2100

Secretary

Terry Scidmore, CPF
The Mitered Corner
206.433.1145

Board Of Directors

Helen Kane, CPF
Anabel's Framing Gallery
425.258.6402

Barbara Mercer, MFA
Edmond's Frame Design
425.771.6520

Ray Miles
National Glass
800.521.7061

Past President

Frank Larson, CPF
Larson Fine Art Services
425.482.0549

This is the final EPFG Newsletter is published by Tim Taricco.
Mailing Address: P. O. Box 411 - Redmond, Washington 98073-0411. **Phone:** (206)235-8467 **Fax:** (630)839-4591
E-mail: frameguy@myframeshop.com **Web Site:** http://www.myframeshop.com. Newsletter Design ©MM T. M. Taricco and Newsletter Content ©MM Evergreen Picture Framers Guild. All rights reserved. Do not duplicate or redistribute in any form.

Need Training for New Employees?

**SEE WHAT YOUR DOLLAR
CAN DO IN CANADA**

**The Canadian Picture
Framer's School**

#1, 20678 Duncan Way
Langley, B.C.

providing excellent thorough
instruction in picture framing for
over 10 years. Phone or fax
for more info:

Ph: 604-533-5328

Fax: 604-533-9680

THANKS FOR THE GOOD TIMES

(Continued from page 1)

the industry anymore, I am turning over the EPFG newsletter to Don Jones of Finishing Touches. He is going to do a great job as the editor of this great newsletter, even though he will be using a Macintosh computer to create it.

Some of you will still see me around as I am doing Web sites for all of you in some way. For some of you I am actually building sites and for everyone else, I will continue to help create the new EPFG Web site.

I'm also going to help with special marketing projects at Colorplak, so continue your support of Colorplak, as it is truly a great company with lots of good people.

Remember, you can always catch me on the Internet at tim@taricco.net or at my new place of work, www.golfphotos.com.



SEATTLE, WA 98133



THE ART DOCTOR

Restoration of Oil Paintings, Japanese Screens,
Art on Paper, Art Objects

NANCY G. WHITE
Restorer

(206) 783-9160
By Appointment



Pacific Framing Supply

"Serving all of your framing needs"

Brad Airhart & John Cave

Salem, OR 97304
Phone: 1-800-872-4445
FAX: 1-503-363-7273

Woodinville, WA 98072
Phone: 1-800-292-3202
FAX: 1-206-486-4978

WILLIAMSON • FDMCORE • TRUVUE GLASS/MILLER MATBOARD
CLARK • DESIGNER WOOD & METAL • COLONIAL • BURNICH

Limited to
stock on hand

WILLIAMSON

Please call for
more info

Discontinued Item Sale

20% OFF LENGTH • 25% OFF CHOPS

16-0420-7277, 16-0420-7377, 38-6464-6304, 38-6464-6306,
38-6464-6309, 40-2210-7277

METAL FRAMES ART



6010 EAST ALKI WAREHOUSE #5
PHONE 800 344-7329 509 535-3440

SPOKANE WASHINGTON 99212
FAX 800 344-5003 509 535-3466



ANAHEIM | DENVER | PORTLAND
SEATTLE | COLORPLAK.COM

Providing art laminating services for frame
shops all over the West coast!

800-305-1953



Hartung Glass was the first company in the Northwest Region to deliver to the Picture Framing Industry. We have been serving the Picture Framers in our area for over twenty years and offer the largest inventory of stock sheets in the Pacific Northwest. We feature all of the top manufacturers, including Sandel, Tru-Vue, and Cyro, with scheduled deliveries to most areas of Washington. We carry many types of framing glass, including:

- | | |
|-----------------|--------------------|
| Clear | Sandel Superior |
| Anti-Reflection | Sandel Crystalview |
| Non-Glare | Tru-Vue & Sandel |
| Conservation | Tru-Vue |
| Preservation | Sandel |
| Museum Glass | Tru-Vue |

Call today to schedule a delivery!

**Hartung now stocks
3/16 mirror with 1" bevel for framing.
Call our helpful customer Service Department today to place your order!**

**425/656-2626
800/552-2227**



Florentina™

A collection of beautiful oxidized colors inspired from the natural earth elements of Florence. The latest addition to the Larson-Juhl Classic Collection.

*For more information on Florentina and other Larson-Juhl framing products call:
(800) 438-5031*

*or contact your Larson-Juhl sales representative
Voice Mail: 800-223-0307*

Stephen Dean - ext. 454 • Joe Garitone - ext. 455 • Paul Anderson - ext. 456

LARSON · JUHL

CUSTOM FRAME THE BEAUTY OF YOUR HOME

NATIONAL GLASS

17030 WOODINVILLE-REDMOND ROAD, WOODINVILLE, WA. 98072

QUALITY PRODUCTS AND EXCELLENT SERVICE! NATIONAL GLASS INVENTORIES THE LARGEST SELECTION OF PICTURE FRAMING GLASS IN THE PACIFIC NORTHWEST.



NATIONAL GLASS

TRU VUE AND SANDEL PREMIUM, REFLECTION CONTROL, SATINVIEW, CONSERVATION SERIES GLASS, IMAGE PERFECT, DENGAS, AND CRYSTALVIEW.

Now Available - AR Glass & Museum Glass!

ALSO AVAILABLE: FOAM-X, MIRROR AND ACRYLICS

EVERYTHING YOU NEED AND FREE DELIVERY ARE ONLY A PHONE CALL AWAY!

(425) 488-8126

1 (800) 521-7061

fax (425) 488-3712



Jeff Schuffman
Sales Representative

1433 W. Frankford Rd. #100 Carrollton, Texas 75007
972-466-0721 • 972-466-3662 Fax
800-527-0421 • 800-817-0524 Fax
Ext. 882



Wholesale Picture
Frame Supplies

2928 4th Ave S • Seattle, WA 98134
206-292-9664
800-423-6287

Software Suite for all Versions of Windows
Galleries & Frame Shops Networking User Friendly!

FERENSOFT
TRIO!

- Art
- Customers
- Framing

Point of Sale and Business Management Software. *Y2K Ready!* See why people are switching to **FS TRIO!** Seattle 206-282-1775
www.ferensoft.com

OUR PRESIDENT'S PEN

(Continued from page 1)

Several months ago, I mentioned the ongoing action to register the term CPF, and here is the latest on that effort. PPFA now has some direction from the attorneys working the issue, and they have provided some instructions for the use of the designation CPF. The process the attorneys are going through is to register the "mark" as a Certification Mark. ^{CM}, or the more familiar Trade Mark (TM) is used when a mark is in the process of application for registration. Once a mark is registered you no longer use the ^{CM} but change to the R with a circle around it, indicating a registered mark. The way the mark is used is also changed, and you have to use something along the lines of this:

Paul Knoop, holder of CPF ^{CM} designation

Because the mark belongs to PPFA, they hold the license to its use, and have given those of us who have passed the CPF exam license to use mark, but we must follow the proscribed acceptable uses. There is a web site set up to see what some of the acceptable uses are: http://www.customframer.com/ppfa/cpf_license.html. Rather than devote any more space to this, I will wait for something from PPFA after final registration is complete and the lawyers get through with their caveats and weasel wording. More to come, but it seems like maybe this is not really going to be a winning situation for us in the long run. A boss of mine once said, "Don't ask the question if you are not prepared to live with the answer"; it's now too late for that.

Don't forget, later this month be sure and look for your voting notice on the PPFA Chapter question. And, hope to see you at the meeting in Queen Anne on the 13th.

TRUE VUE GLASS
FOR EVERYTHING YOU NEED

<p>PREMIUM SERIES GLASS</p> <ul style="list-style-type: none"> • PREMIUM CLEAR* • REFLECTION CONTROL* • ART* REFLECTIVE FREE 	<p>CONSERVATION SERIES GLASS</p> <ul style="list-style-type: none"> • CONSERVATION CLEAR* • CONSERVATION REFLECTION CONTROL* • MUSEUM GLASS*
--	--

Fabric & Liners

The softer Side of Framing

Hundreds of colors and textures---- Exclusive pH Neutral Fabrics

Frank's Fabrics for Framers

Dial Toll-Free (888) F.FABRIX (332-2749)



FRAMERS' INVENTORY

WOOD MOULDING

Bay, Framers' Inventory, LaMarche, Max, Roma

METAL MOULDING

Nielsen

MATBOARD

Bainbridge, Crescent, Rising, TruVue

GLASS & FOAMBOARD

Sandel, TruVue
Bainbridge, Bienfang, & Hart

EQUIPMENT

C&H, Eclipse, Fletcher
Mitre Mite VN42, Seal/Hunt Mounting

SERVICE

Daily delivery in Portland & Seattle Metro areas,
Overnight chop service

5000 SE 18TH AVENUE, PORTLAND, OREGON 97202
LOCAL (503)236-9293 · TOLL FREE(800)543-2467
FAX(503)236-3899



8214-B South 192nd St., Kent, WA 98032

FREE FREIGHT

On all orders over \$100.00 in OR and WA

JOE HUBER

Orders: (800) 262-4174
Voice Mail Ext: 217
Fax: (888) 423-1814



CORONA

1150 Industry Drive Tukwila, WA 98188
Division of RCI, Inc.



The choice of professionals, CORONA Cold & Hot/Cold Vacuum presses. Complete mounting/laminating supplies. Originators of BERTO and Corona Hot/Cold Unimount adhesives...the industry mainstays for over 20 years. 'The Mounting Specialists'.

Suppliers to the Picture Framing Industry for over
30 years

206.575.2727 Fax: 206.575.2667

Chances are you started out with a LOGAN Mat Cutter Have you seen what we've done lately?

NEW!

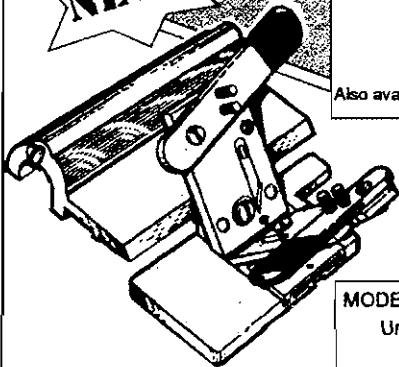

Model 705
Logan
V-Groover

MODEL #650 *Framer's Edge* MAT CUTTER 40" Professional Production Matcutter

- Includes:
- Ergonomically designed Dual straight and Bevel cutting head
 - Production Stops
 - Parallel Mat Guide
 - Start and Stop Indicator for line to line cutting.
 - 27" Squaring Arm

Suggested List Price \$599.95

Also available in a 60" version MODEL #660 *Framer's Edge* \$799.95

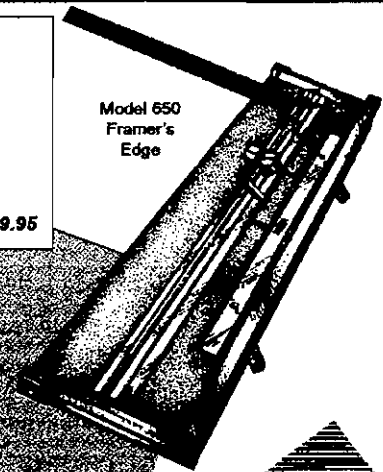

Model 650
Framer's
Edge

MODEL 705 LOGAN V-Groover ^{patented}

Unique "push-pull" surface V-Groover that cuts beautiful V-Grooves on the surface of the matboard. Works entirely with stops provided for accurate V-Grooving in seconds with zero overcuts. Endless creative possibilities!!

Suggested List Price \$125.00

MODEL 706 Universal V-Groover ^{patented}

Works on professional mat cutters using a 5/8" thick cutting bar rod including Fletcher® and C&H® professional matcutters.

Suggested List Price \$150.00





GRAPHIC PRODUCTS, INC.
1100 BROWN STREET • WALICONDA, ALABAMA 36084
NATIONWIDE TOLL FREE 1-800-231-4232
TOLL FREE FAX 800/331-4329

See us at <http://www.artproducts.com>
E-mail: Logan-Graphic-Products@worldnet.att.net



It's About Choices...

 Crescent Regular Matboard, with the greatest array of colors, is the **right choice** for everyday decorative framing. Crescent Whiteout Basics, with its non-yellowing white core, is the **ideal choice** for the design requirements of today's contemporary decor. Crescent Rag Mat remains the **only choice** for conservation framing. With its naturally 100% acid- and lignin-free cotton core  it's the premier choice for preserving precious works of art and irreplaceable memories.

Crescent
 We Give You THE RIGHT CHOICES!
<http://www.crescent-cardboard.com>

Crescent Cardboard Company, 100 West Yellow Road, Wheeling, Illinois 60090, Tel. 1-847-537-3400, Fax 1-847-537-7153

NURRE CAXTON

FRAMERS OF DISTINCTION



*"We're Obsessed
With Customer
Satisfaction"*

Pamela Neal
Sales Representative for
Washington, Wyoming, Montana
Oregon and Idaho

1-800-255-1942, press 6, ext. 4011
for voice mail
1-800-377-3300 fax
1-800-910-8966 pager

We promise friendly, reliable service
same day shop service, free UPS
for orders of 3 shops or more
(aluminum and Nurre metal combined)

MEMBERSHIP APPLICATION & UPDATE FORM

Company Name:

Phone:

Contact Name:

Fax:

Street Address:

E-Mail:

City:

Web Site: <http://>

State:

Zip:

Complete this form and return it with your membership dues of \$40.

Mail to: Lynn Clark, c/o Lake City Picture Framing, 14028 Lake City Way NE, Seattle, WA 98125

For more information about the Evergreen Picture Framers Guild, please contact: Paul Knoop, c/o The Framemakers, 6724 West 19th, University Place, WA 98466, 253.564.2320, pknoop@earthlink.net

Mark your
calendars for all the
fun events that
EPFG has planned
for you in August.

June 2000

13th – General Meeting – 7 PM
Museum Quality Framing—
Queen Anne location

“The Future of Framing”
A group discussion

July 2000

11th – General Meeting – 7 PM
Anabel's Framing Gallery—
Everett

“Taxes & Small Business”

August 2000

13th – Everett AquaSox Base-
ball game & picnic—6 PM
\$18 Adult, \$13 ages 3–12

20th – Best Ball Golf Tourna-
ment—Wilderness Golf
Course— \$38 per golfer

September 2000

12th – General Meeting – 7 PM
William Bounds Custom
Framing—Burlington

October 2000

10th – General Meeting – 7 PM

November 2000

14th – General Meeting – 7 PM
Colorplak—Redmond

December 2000

No Meeting

Museum Quality Framing
2128 Queen Anne N
Seattle, WA 98109-2359
(206) 285-9656

Directions to the meeting: Take the MERCER Exit off I-5 in downtown Seattle. Turn RIGHT onto FAIRVIEW AVE N. Turn LEFT onto VALLEY ST. VALLEY ST becomes BROAD ST. Turn SLIGHT RIGHT onto HARRISON ST. Turn RIGHT onto 5TH AVE N. Turn LEFT onto ROY ST. Turn RIGHT onto QUEEN ANNE AVE N.



Paul Knoop
2118 South 373rd Court
University Place, WA 98466

SEE PAGE TWO OF THIS
NEWSLETTER FOR ADDRESS
CHANGE CONTACT INFORMATION

ATTENTION: FRAME SHOP